

**GOODWE**



# **User Manual**

**Grid-Tied PV Inverter**

UT Series

V1.2-2024-07-19

**Copyright ©GoodWe Technologies Co.,Ltd. 2024. All rights reserved.**

No part of this manual can be reproduced or transmitted to the public platform in any form or by any means without the prior written authorization of GoodWe Technologies Co.,Ltd.

**Trademarks**

**GOODWE** and other GOODWE trademarks are trademarks of GoodWe Technologies Co.,Ltd. All other trademarks or registered trademarks mentioned in this manual are owned by the company.

**NOTICE**

The information in this user manual is subject to change due to product updates or other reasons. This manual cannot replace the safety instructions or labels on the equipment unless otherwise specified. All descriptions here are for guidance only.

# CONTENT

<b>1</b>	<b>About This Manual</b>	<b>1</b>
1.1	Applicable Model	1
1.2	Target Audience	1
1.3	Symbol Definition	1
<b>2</b>	<b>Safety Precaution</b>	<b>2</b>
2.1	General Safety	2
2.2	PV String Safety	2
2.3	Inverter Safety	3
2.4	Personnel Requirements	3
2.5	EU Declaration of Conformity	4
<b>3</b>	<b>Product Introduction</b>	<b>5</b>
3.1	Product Overview	5
3.2	Supported Grid Types	5
3.3	Features	6
3.4	Circuit Diagram	8
3.5	Appearance	9
3.5.1	Parts	9
3.5.2	Dimensions	11
3.5.3	Indicators	11
3.5.4	Nameplate	12
<b>4</b>	<b>Check and Storage</b>	<b>13</b>
4.1	Check Before Receiving	13
4.2	Deliverables	13
4.3	Storage	14
<b>5</b>	<b>Installation</b>	<b>15</b>
5.1	Installation Requirements	15
5.2	Inverter Installation	18
5.2.1	Moving the Inverter	18
5.2.2	Installing the Inverter	18
5.2.3	Installing the Inverter	20
<b>6</b>	<b>Electrical Connection</b>	<b>22</b>

6.1 Safety Precaution .....	22
6.2 Connecting the PE cable.....	24
6.3 Connecting the PV Input Cable .....	24
6.4 Connecting the AC Output Cable .....	26
6.5 Communication Connection .....	30
6.5.1 Connecting RS485 Communication Cable .....	30
6.5.2 Connecting PLC Communication Cable.....	34
6.5.3 Installing the Communication Dongle (Optional).....	35
<b>7 Equipment Commissioning .....</b>	<b>36</b>
7.1 Check Before Power ON .....	36
7.2 Power On.....	36
<b>8 System Commissioning .....</b>	<b>37</b>
8.1 Indicators and Buttons.....	37
8.2 Setting Inverter Parameters via LCD .....	38
8.3 Setting Inverter Parameters via App .....	40
8.4 Monitoring via SEMS Portal .....	40
<b>9 Maintenance .....</b>	<b>41</b>
9.1 Power OFF the Inverter .....	41
9.2 Removing the Inverter.....	41
9.3 Disposing of the Inverter .....	41
9.4 Troubleshooting .....	42
9.5 Routine Maintenance.....	48
<b>10 Technical Parameters .....</b>	<b>49</b>



# 1 About This Manual

This manual describes the product information, installation, electrical connection, commissioning, troubleshooting, and maintenance. Read through this manual before installing and operating the product. All the installers and users have to be familiar with the product features, functions, and safety precautions. This manual is subject to update without notice. For more product details and latest documents, visit <https://en.goodwe.com>.

## 1.1 Applicable Model

This manual applies to the listed inverters below (UT for short) :



Model	Nominal Output Power	Nominal Output Voltage
GW250KH-UT	250kW	800V,3L/PE
GW320K-UT	320kW	
GW320KH-UT		
GW320KH-UT-KR		
GW350K-UT	350kW	
GW350KH-UT		

## 1.2 Target Audience

This manual applies to trained and knowledgeable technical professionals. The technical personnel has to be familiar with the product, local standards, and electric systems.

## 1.3 Symbol Definition

Different levels of warning messages in this manual are defined as follows:

 <b>DANGER</b>
Indicates a high-level hazard that, if not avoided, will result in death or serious injury.
 <b>WARNING</b>
Indicates a medium-level hazard that, if not avoided, could result in death or serious injury.
 <b>CAUTION</b>
Indicates a low-level hazard that, if not avoided, could result in minor or moderate injury.
<b>NOTICE</b>
Highlights key information and supplements the texts. Or some skills and methods to solve product-related problems to save time.

## 2 Safety Precaution

### WARNING

The inverters are designed and tested strictly to comply with related safety rules. Read and follow all the safety instructions and cautions before any operations. Improper operation might cause personal injury or property damage as the inverters are electrical equipment.

### 2.1 General Safety

#### NOTICE

- The information in this user manual is subject to change due to product updates or other reasons. This manual cannot replace the safety instructions or labels on the equipment unless otherwise specified. All descriptions here are for guidance only.
- Before installations, read through the user manual to learn about the product and the precautions.
- All operations should be performed by trained and knowledgeable technicians who are familiar with local standards and safety regulations.
- Use insulating tools and wear personal protective equipment when operating the equipment to ensure personal safety. Wear anti-static gloves, clothes, and wrist strips when touching electronic devices to protect the inverter from damage.
- Strictly follow the installation, operation, and configuration instructions in this manual. The manufacturer shall not be liable for equipment damage or personal injury if you do not follow the instructions. For more warranty details, please visit <https://en.goodwe.com/warranty>.

### 2.2 PV String Safety

#### DANGER

- Connect the DC input cables using the included PV connectors or terminals. Severe damage might happen if other types of PV connectors or terminals are used, which is beyond the manufacturer's liability.
- Do not connect the inverter to PV string that requires positive or negative grounding.

#### WARNING

- Ensure the component frames and the bracket system are securely grounded.
- Ensure the DC cables are connected tightly, securely and correctly.
- Measure the DC cables with a multimeter to avoid reverse polarity connection. Also, the voltage should be under the permissible range.
- Do not connect one PV string to more than one inverter at the same time. Otherwise, it may damage the inverter.
- Ensure that the positive or negative poles of the PV string do not short-circuit to the ground. Otherwise, severe damage might happen, which is beyond the manufacturer's liability.
- The two input strings per MPPT should be of the same type and number of modules. The manufacturer shall not be liable for the module damage if the number of modules in one string is 10% or more less than number of modules in other strings.









## 2.3 Inverter Safety

 **WARNING**

- The voltage and frequency at the connection point meet the inverter grid connection requirements.
- Additional protective devices like circuit breakers or fuses are recommended on the AC side. Specification of the protective device should be at least 1.6 times the maximum AC output current.
- Make sure that all the grounding cables are tightly connected. When there are multiple inverters, make sure that all the grounding points on the enclosures are equipotential connected.
- You are recommended to use copper cables as AC output cables. A copper to aluminum adapter terminal is required when an aluminum cable is used.

 **DANGER**

- Do not apply mechanical load to the terminals, otherwise the terminals can be damaged.
- All labels and warning marks should be visible after the installation. Do not scrawl, damage, or cover any label on the device.
- Warning labels on the inverter are as follows.

	DANGER High voltage hazard. Disconnect all incoming power and turn off the product before working on it.		Delayed discharge. Wait 5 minutes after power off until the components are completely discharged.
	Read through the user manual before any operations.		Potential risks exist. Wear proper PPE before any operations.
	High-temperature hazard. Do not touch the product under operation to avoid being burnt.		Grounding point.
	CE Mark		Do not dispose of the inverter as household waste. Discard the product in compliance with local laws and regulations, or send it back to the manufacturer.

## 2.4 Personnel Requirements

**NOTICE**

- Personnel who install or maintain the equipment must be strictly trained, learn about safety precautions and correct operations.
- Only qualified professionals or trained personnel are allowed to install, operate, maintain, and replace the equipment or parts.

## 2.5 EU Declaration of Conformity

GoodWe Technologies Co., Ltd. hereby declares that the inverter with wireless communication modules sold in the European market meets the requirements of the following directives:

- Radio Equipment Directive 2014/53/EU (RED)
- Restrictions of Hazardous Substances Directive 2011/65/EU and (EU) 2015/863 (RoHS)
- Waste Electrical and Electronic Equipment 2012/19/EU
- Registration, Evaluation, Authorization and Restriction of Chemicals (EC) No 1907/2006 (REACH)

GoodWe Technologies Co., Ltd. hereby declares that the inverter without wireless communication modules sold in the European market meets the requirements of the following directives:

- Electromagnetic compatibility Directive 2014/30/EU (EMC)
- Electrical Apparatus Low Voltage Directive 2014/35/EU (LVD)
- Restrictions of Hazardous Substances Directive 2011/65/EU and (EU) 2015/863 (RoHS)
- Waste Electrical and Electronic Equipment 2012/19/EU
- Registration, Evaluation, Authorization and Restriction of Chemicals (EC) No 1907/2006 (REACH)

You can download the EU Declaration of Conformity on <https://en.goodwe.com>.

## 3 Product Introduction

### 3.1 Product Overview

The UT Series inverter is a three-phase PV string grid-tied inverter. The inverter converts the DC power generated by the PV module into AC power and feeds it into the utility grid. The intended use of the inverter is as follows:

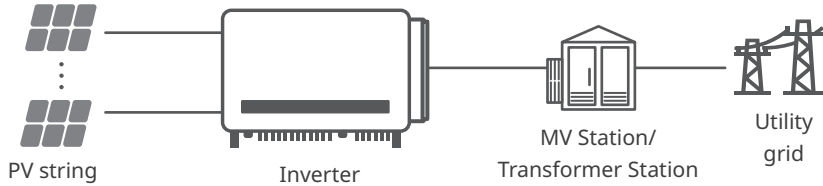

### 3.2 Supported Grid Types

The UT inverter supports IT grid type.

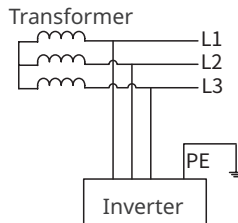

## 3.3 Features

### Power derating

For a safe operation, the inverter will automatically reduce the output power when the operating environment is not ideal.

The following are the factors that may occur power derating. Please try to avoid them when the inverter is working.

- Unfavorable environmental conditions, e.g., direct sunlight, high temperature, etc.
- Inverter's output power percentage has been set.
- Over-frequency derating.
- Higher input voltage value.
- Higher input current value.

Example: output power derating due to altitude change

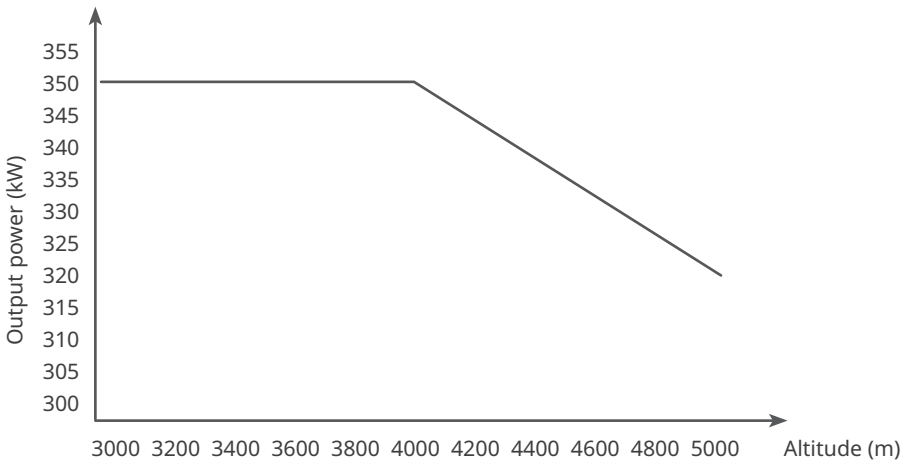

### Reactive power control At night (SVG, optional)

To improve the power generation performance of the power station, the inverter supports night SVG function. Issuing a reactive power compensation command via the power station monitoring platform, which makes the inverter keep working even when there is no active power output.

### Weak grid support

Short circuit ratio (SCR) of the grid system determines the strength of the grid. The grid is defined as a weak grid when SCR is less than 10.

The weak grid support function keeps the inverter be on-grid and output current steadily even when the SCR is higher than 1.0.

### Replace the fan on-grid

Disconnect a single inverter from the utility grid and change its fan, which means the power generation of other inverters in the power station will not be influenced.

### Potential Induced Degradation (PID, optional)

When the inverter is connected to the grid, the potential difference between the negative pole of the PV array and the module frame decreases the energy generated by the PV modules. That is the PID effect.

- Anti-PID function

The inverter rises the voltage of the negative pole of the PV array to ground through the PID module. When the voltage to ground is close to zero, the PID effect is suppressed.

- PID recovery function

The inverter rises the voltage of the negative pole of the PV array to ground to approx. 1/2 DC BUS voltage through the PID module to recover the PID effect.

Anti-PID function and PID recovery function can work properly only when the inverter is applied to an IT system.

#### Note:

- PID recovery and SVG cannot be activated simultaneously.
- PID recovery may cause false alarms in the insulation monitoring function of the MVS.

### AFCI (Standard feature for GW320KH-UT-KR, and optional feature for other models)

Reasons to occur electric arcs.

- Damaged connectors in the PV or battery system.
- Wrong connected or broken cables.
- Aging connectors and cables.

Methods to detect electric arcs.

- The inverter has an integrated AFCI function.
- When the inverter detects an electric arc, users can find the time of the fault and the detailed phenomenon through the app.
- The alarm can be cleared automatically if the inverter triggers a fault for less than 5 times within 24 hours. The inverter will shutdown for protection after the 5th electric arc fault. The inverter cannot work normally until the fault is solved. Please refer to the SolarGo App User Manual for detailed operations.

### 3.4 Circuit Diagram

#### GW250KH-UT/GW320KH-UT/GW320KH-UT-KR/GW350KH-UT

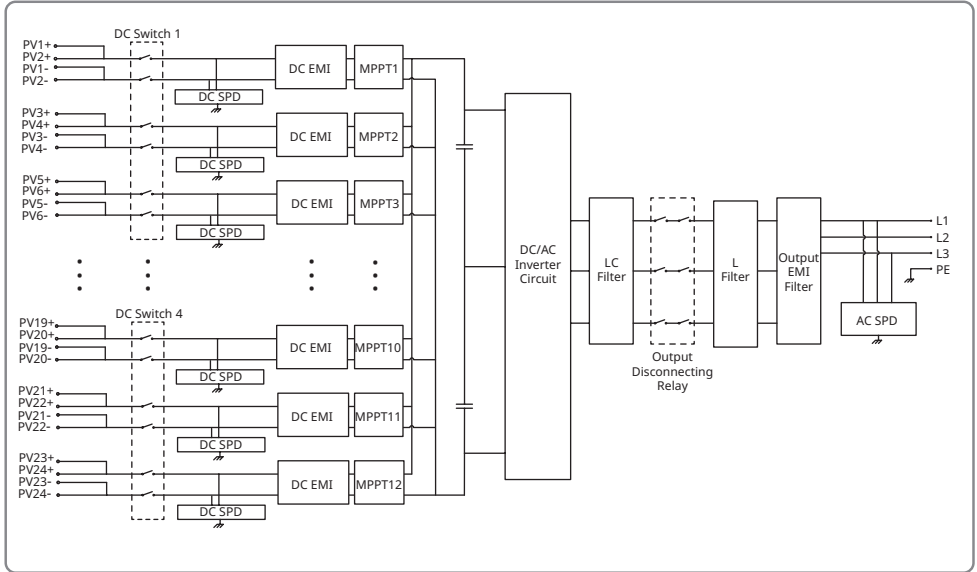

#### GW320K-UT/GW350K-UT

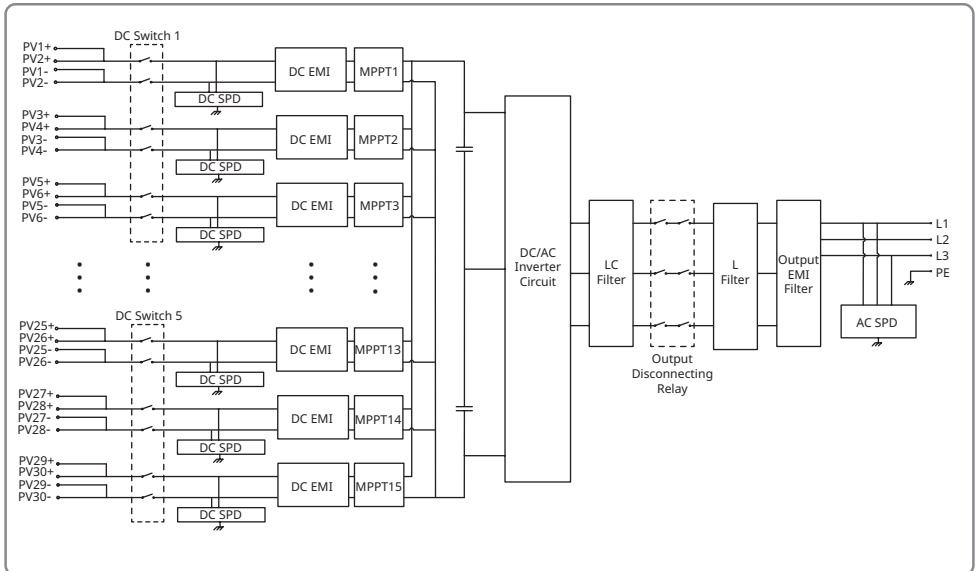



## 3.5 Appearance

### 3.5.1 Parts

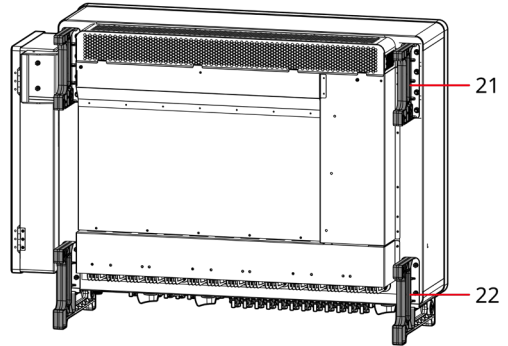
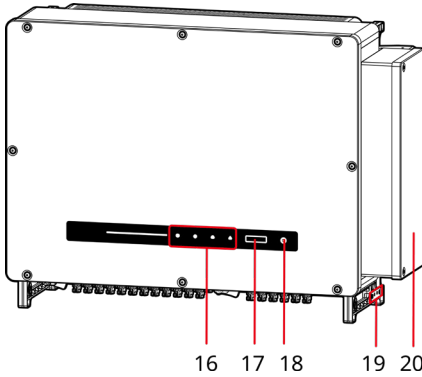
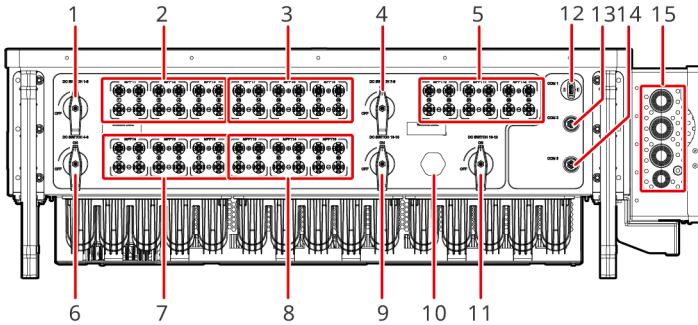

No.	Parts	Description
1	DC switch 1-3 (DC SWITCH 1-3)	Controls PV input terminal 1-3 (MPPT 1-3) to connect or disconnect the PV string.
2	PV input terminal 1-3 (MPPT1-3)	Controlled by DC switch 1-3. Used to connect the PV strings.
3	PV input terminal 7-9 (MPPT7-9)	Controlled by DC switch 7-9. Used to connect the PV strings.
4	DC switch 7-9 (DC SWITCH 7-9)	Controls PV input terminal 7-9 (MPPT 7-9) to connect or disconnect the PV string.
5	PV input terminal 10-12 (MPPT10-12)	Controlled by DC switch 10-12. Used to connect the PV strings.
6	DC switch 4-6 (DC SWITCH 4-6)	Controls PV input terminal 4-6 (MPPT 4-6) to connect or disconnect the PV string.
7	PV input terminal 4-6 (MPPT4-6)	Controlled by DC switch 4-6. Used to connect the PV strings.

No.	Parts	Description
8	PV input terminal 13-15 (MPPT13-15) (Only for GW320K-UT/ GW350K-UT)	Controlled by DC switch 13-15. Used to connect the PV strings. Only for GW320K-UT and GW350K-UT.
9	DC switch 13-15 (DC SWITCH 13-15)	Controls PV input terminal 13-15 (MPPT 13-15) to connect or disconnect the PV string. Only for GW320K-UT and GW350K-UT.
10	Ventilation valve	-
11	DC switch 10-12 (DC SWITCH 10-12)	Controls PV input terminal 10-12 (MPPT 10-12) to connect or disconnect the PV string.
12	Communication module port (COM1)	Connects a communication module, like a Bluetooth or WiFi module.
13	RS485 communicaiton port (COM2)	For RS485 communication between inverters, a smart communication unit, or a smart datalogger.
14	Remote shutdown or emergency shutdown communication port (COM3)	Connects communication cable for remote shutdown or emergency shutdown. Remote shutdown for Europe. Emergency shutdown for India.
15	AC cable outlet hole	Route the AC output cables through the cable outlet hole.
16	LED Indicator	Indicates working state of the inverter.
17	LCD (optional)	Optional. To check the parameters of the inverter.
18	Button (optional)	Optional. To control contents displayed on the screen.
19	Grounding point	Connects grounding cables to the grounding points for protection.
20	AC cable wiring box	Protects the AC output cables. Connects or disconnects the AC cables after opening the AC wiring box.
21	Mounting handles	Two mounting handles To attach the handles, move the inverter, and hand the inverter to the mounjting bracket.
22	Bottom handles	Two bottom handles. To attach the handles, move the inverter, and hand the inverter to the mounjting bracket.

### 3.5.2 Dimensions

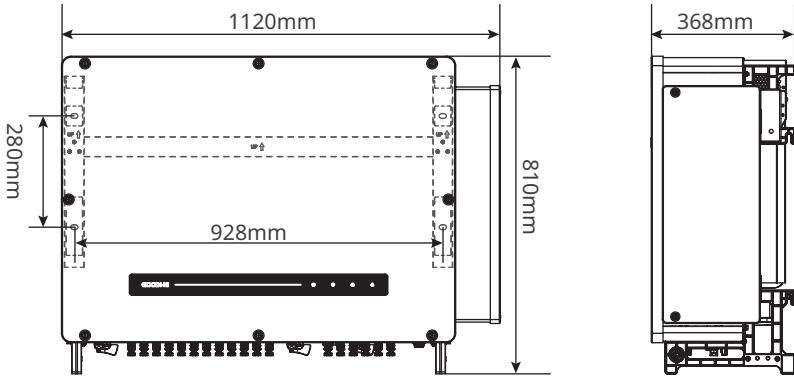

### 3.5.3 Indicators

Indicator	Status	Description
⏻		ON= EQUIPMENT POWER ON
		OFF= EQUIPMENT POWER OFF
▶		ON= THE INVERTER IS FEEDING POWER
		OFF= THE INVERTER IS NOT FEEDING POWER
		SINGLE SLOW FLASH= SELF CHECK BEFORE CONNECTING TO THE GRID
☁		SINGLE FLASH = CONNECTING TO THE GRID
		ON= WIRELESS IS CONNECTED/ACTIVE
		BLINK 1 = WIRELESS SYSTEM IS RESETTING
		BLINK 2 = WIRELESS ROUTER PROBLEM
		BLINK 4 = WIRELESS SERVER PROBLEM
⚠		BLINK = RS485 IS CONNECTED
		OFF= WIRELESS IS NOT ACTIVE
		ON= A FAULT HAS OCCURRED
		OFF= NO FAULT

### 3.5.4 Nameplate

The nameplate is for reference only.

<b>GOODWE</b>	
<b>Product: Grid-Tied PV Inverter</b> <b>Model : GW****-UT</b>	
PV Input	UDCmax: **** Vd.c.
	UMPP: ***...***Vd.c.
	IDC,max: **Ad.c.
	ISC PV:**Ad.c
Output	UAC, r: 3L/PE-800V a.c.
	fAC, r: **Hz
	PAC,r: W k
	IAC,max: **Aa.c.
	Sr: *** kVA
	Smax: ***kVA
P.F.: -1,0.8cap...0.8ind,Toperating: -35--+60°C ALT: 5000m (>4000m derating) Non-isolated , IP66, Protective Class I, OVC DCII/ACIII	
S/N:	
GoodWe Technologies Co., Ltd. E-mail: service@goodwe.com No.9 0 Zijin Rd., New District, Suzhou, 215011, China S/N	

GOODWE trademark, product type, and product model

Technical parameters

Safety symbols and certification marks

Contact information and serial number

## 4 Check and Storage

### 4.1 Check Before Receiving

Check the following items before receiving the product.

Check the outer packing box for damage, such as holes, cracks, deformation, and other signs of equipment damage. Do not unpack the package and contact the supplier as soon as possible if any damage is found.

Check the inverter model. If the inverter model is not what you requested, do not unpack the product and contact the supplier.

Check the deliverables for correct model, complete contents, and intact appearance. Contact the supplier as soon as possible if any damage is found.

### 4.2 Deliverables

#### NOTICE

\* The bluetooth module is optional, and delivered individually.

- Connect the DC cables with the delivered PV connectors. The manufacturer shall not be liable for the damage if other terminals are used.
- N represents the accessories' quantity delivered varies depending on the specific inverter type. The number of PV connectors and the PV terminals in the inverter is the same.

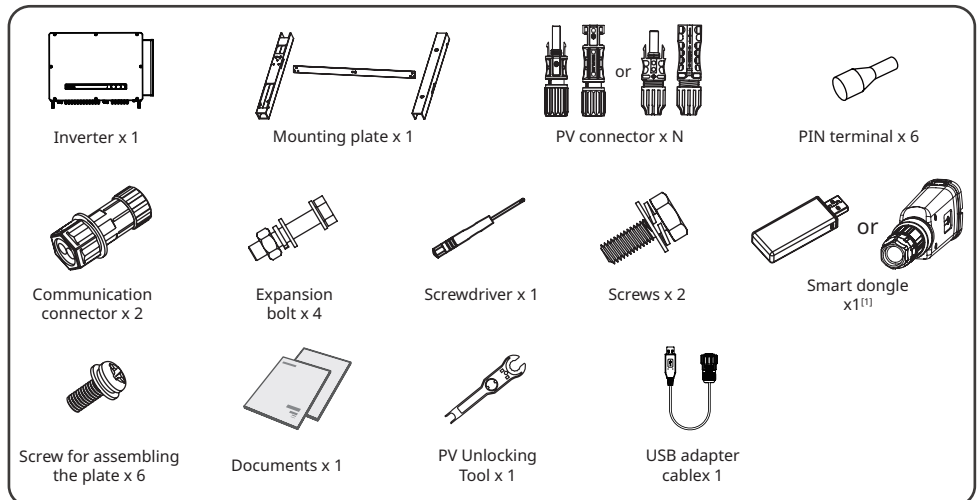

- N : Quantity depends on the inverter model.
- [1] : Smart dongle is optional and delivered separately.

## 4.3 Storage

### NOTICE

The storage time of the inverter should not exceed two years. If the storage time exceeds two years, it must be inspected and tested by professionals before being put into use.

If the equipment is not to be installed or used immediately, please ensure that the storage environment meets the following requirements:

1. Do not unpack the outer package or throw the desiccant away.
2. Store the equipment in a clean place. Make sure the temperature and humidity are appropriate and no condensation.
3. The height and direction of the stacking inverters should follow the instructions on the packing box.
4. The inverters must be stacked with caution to prevent them from falling.
5. If the inverter has been long term stored, it should be checked by professionals before being put into use.

# 5 Installation

## 5.1 Installation Requirements

### Installation Environment Requirements

1. Do not install the equipment in a place near flammable, explosive, or corrosive materials.
2. Install the equipment on a surface that is solid enough to bear the inverter weight.
3. Install the equipment in a well-ventilated place to ensure good dissipation. Also, the installation space should be large enough for operations.
4. The equipment with a high ingress protection rating can be installed indoors or outdoors. The temperature and humidity at the installation site should be within the appropriate range.
5. Recommended install the equipment in a sheltered place to avoid direct sunlight, rain, and snow. Build a sunshade if it is needed.
6. Do not install the equipment in a place that is easy to touch, especially within children's reach. High temperature exists when the equipment is working. Do not touch the surface to avoid burning.
7. Install the equipment at a height that is convenient for operation and maintenance, electrical connections, and checking indicators and labels.
8. Install the equipment far away from noise-sensitive areas, such as residential areas, schools, hospitals, etc, to avoid the noise from bothering people nearby.
9. Consult the manufacturer before installing the equipment outdoors in salt affected areas. A salt affected area refers to the region within 500 meters offshore, and will be related to the sea wind, precipitation and topography.
10. Install the equipment away from electromagnetic interference. If there is any radio or wireless communication equipment below 30MHz near the equipment, you have to:
  - Add a multi-turn winding ferrite core at the DC input line or AC output line of the inverter, or add a low-pass EMI filter.
  - Install the inverter at least 30m far away from the wireless equipment.

### Mounting Support Requirements

- The mounting support shall be nonflammable and fireproof.
- Install the equipment on a surface that is solid enough to bear the inverter weight.
- Do not install the equipment on the support with poor sound insulation to avoid the noise generated by the working equipment, which may annoy the residents nearby.

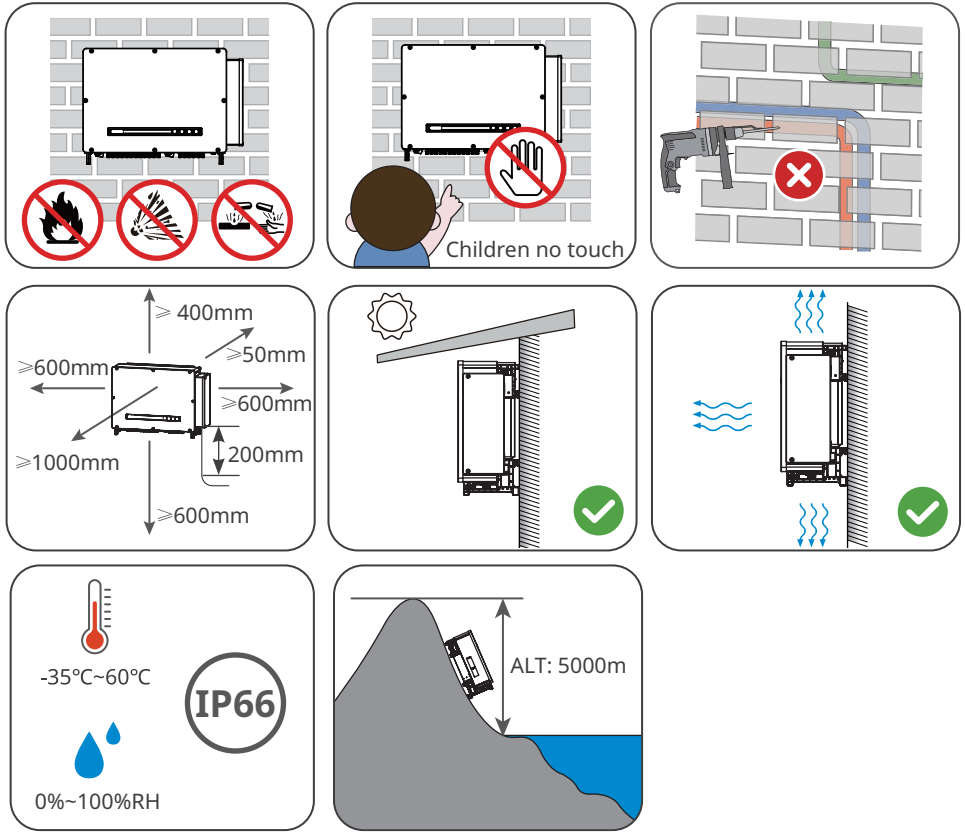

**Installation Angle Requirements**

- Install the inverter vertically or at a maximum back tilt of 10 degrees.
- Do not install the inverter upside down, forward tilt, backward tilt, or horizontally.

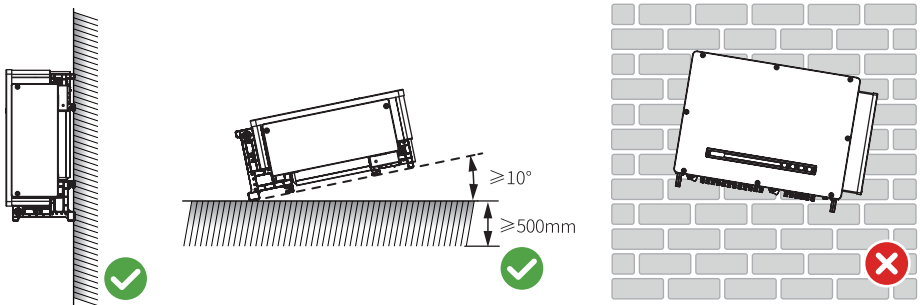



## Installation Space Requirements

- Horizontal installation

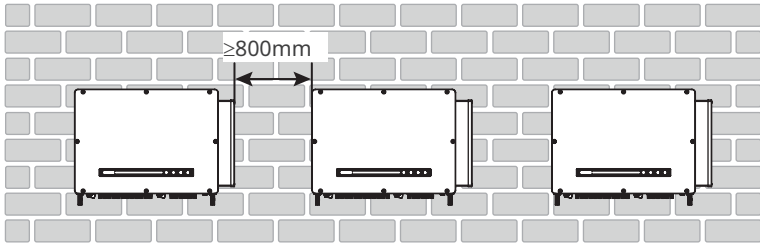

## Installation Tool Requirements

The following tools are recommended when installing the equipment. Use other auxiliary tools on site if necessary.



## 5.2 Inverter Installation

### 5.2.1 Moving the Inverter

#### ⚠ CAUTION

Move the inverter to the site before installation. Follow the instructions below to avoid personal injury or equipment damage.

1. Consider the weight of the equipment before moving it. Assign enough personnel to move the equipment to avoid personal injury.
2. Wear safety gloves to avoid personal injury.
3. Keep balance to avoid falling down when moving the equipment.

### 5.2.2 Installing the Inverter

#### Assembling the mounting plate

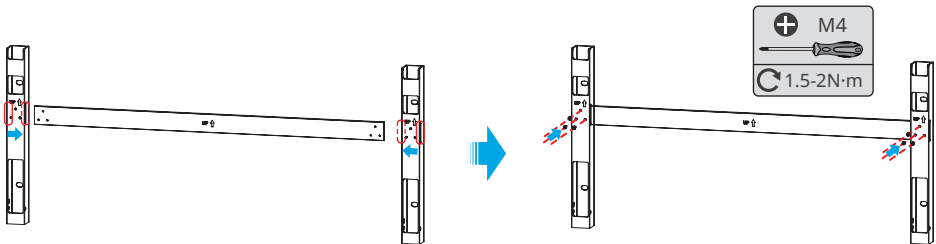

#### NOTICE

- Avoid the water pipes and cables buried in the wall when drilling holes.
- Wear goggles and a dust mask to prevent the dust from being inhaled or contacting eyes when drilling holes.
- Prepare and secure the mounting bracket if you want to install the inverter on the bracket.
- If you need to use the handles or hoisting rings, please contact after-sale service for purchase.

**Step 1** Put the plate on the wall horizontally and mark positions for drilling holes.

**Step 2** Drill holes to a depth of 65mm using the hammer drill. The diameter of the drill bit should be 13mm.

**Step 3** Fix the mounting plate on the wall or the bracket.

### Wall mounting

Avoid the water pipes and cables buried in the wall when drilling holes.  
The M10 expansion bolts should be prepared by customers.

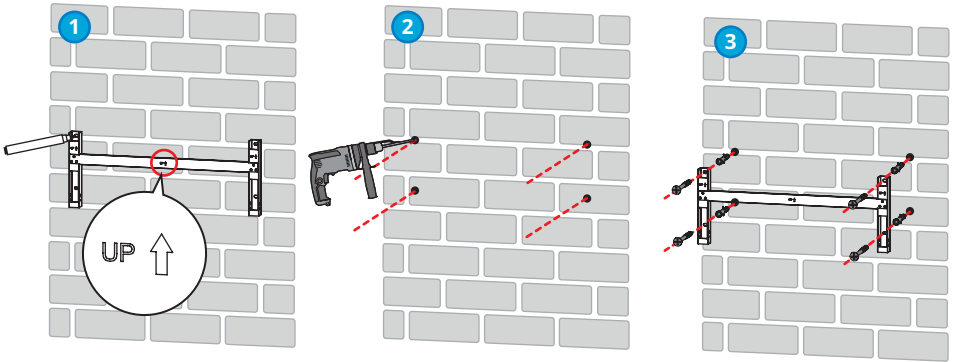

### Bracket mounting

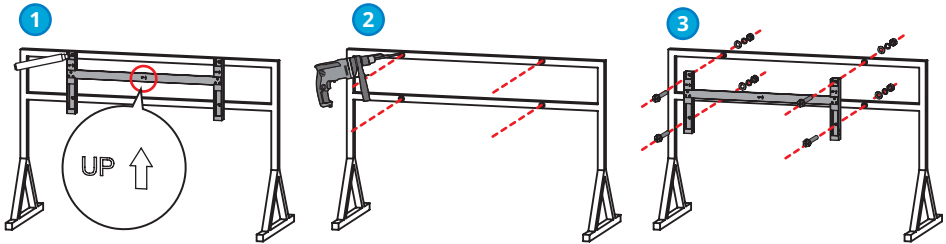

### Pole mounting

**NOTICE**

The column, clamp, and other accessories are self-prepared.

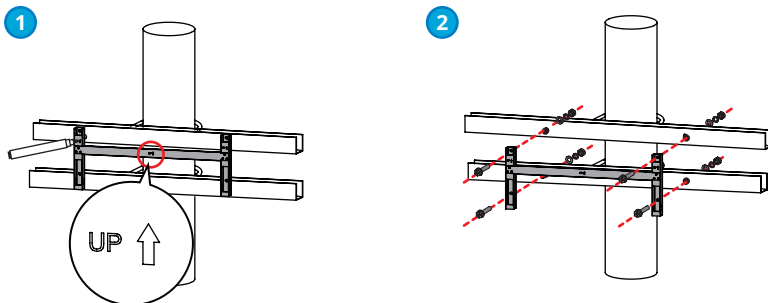

## 5.2.3 Installing the Inverter

**Step 1** Install the handles or hoist rings to the sides of the inverter.

**Step 2** Grab the handles to lift or hoist the inverter to place it on the mounting plate.

**Step 3** Tighten the nuts to secure the mounting plate and the inverter.

### Lifting the Inverter

#### CAUTION

Follow the instructions below to avoid personal injury or equipment damage:

- Consider the weight of the equipment before moving it. Assign enough personnel to move the equipment to avoid personal injury.
- Make sure all four handles are securely mounted and can withstand the weight of the equipment.
- Grab the handle only when moving the equipment. Never use the terminals or base as a handle.

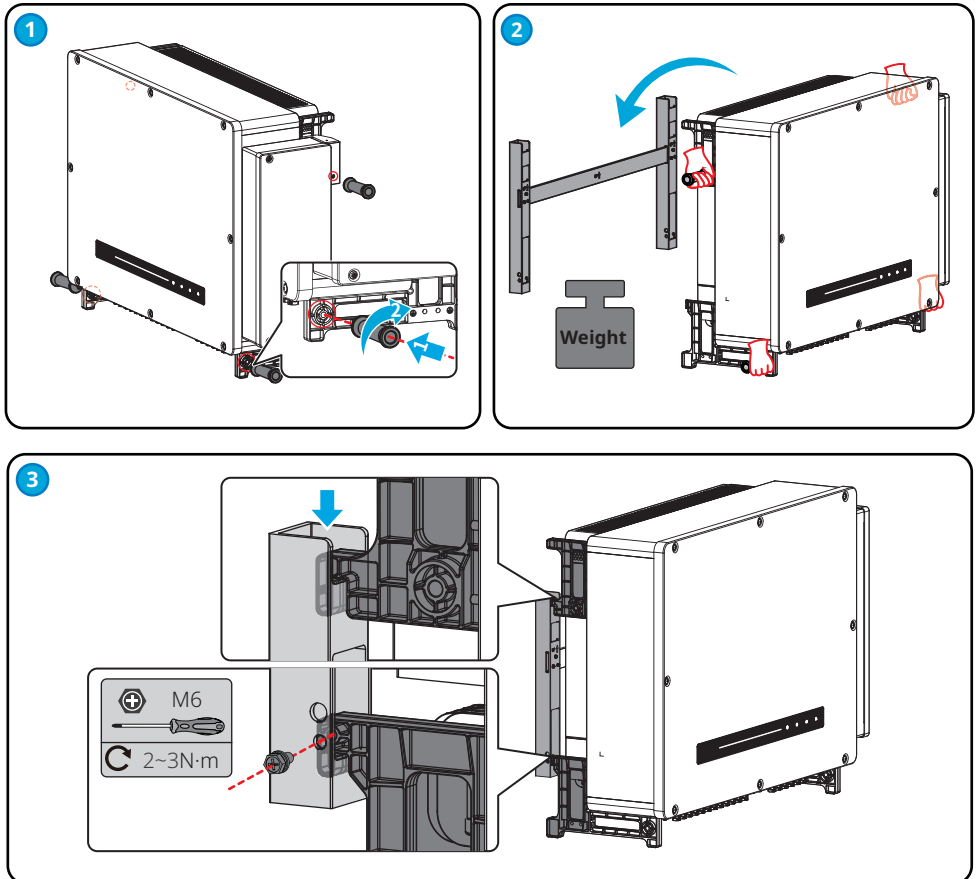

## Hoisting the Inverter

### CAUTION

Follow the instructions below to avoid personal injury or equipment damage:

- Connect the rope and the equipment correctly as the following steps and make sure the ropes are safely connected.
- Make sure the hoisting rings and ropes can hold the equipment.
- Never use the terminals or base of the equipment as a rope connection point.

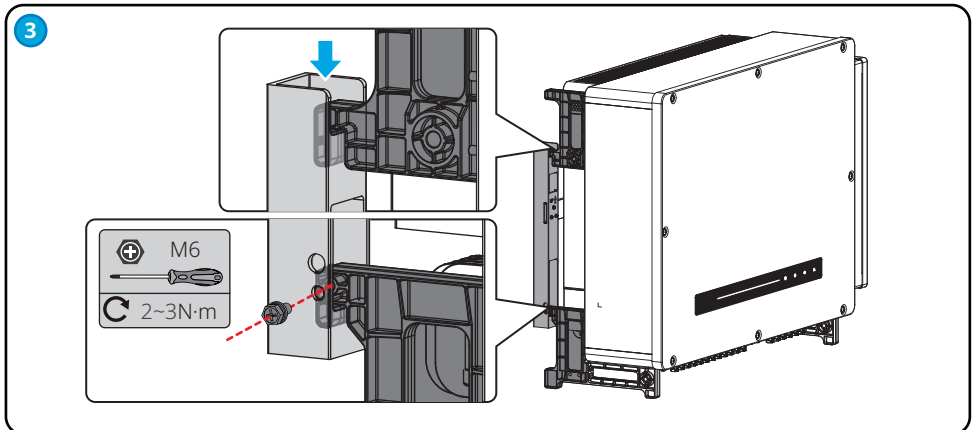
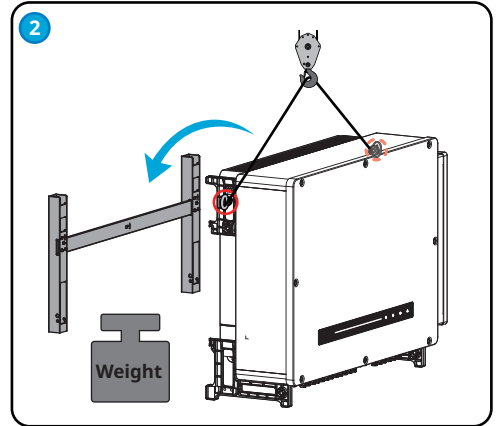
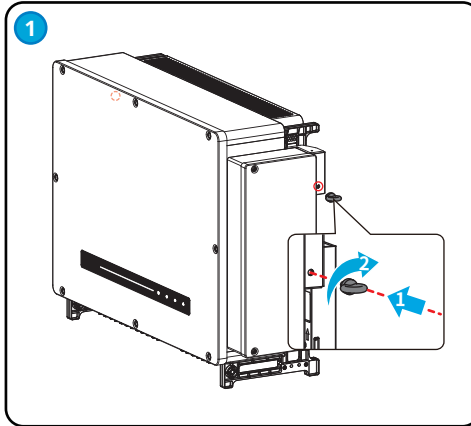

## 6 Electrical Connection

### 6.1 Safety Precaution

#### DANGER

- Disconnect the DC switch and the AC breaker of the inverter to power off the inverter before any electrical connections. Do not work with power on. Otherwise, an electric shock may occur.
- Perform electrical connections in compliance with local laws and regulations. Including operations, cables, and component specifications.
- If the cable bears too much tension, the connection may be poor. Reserve a certain length of the cable before connecting it to the inverter cable port.

#### NOTICE

- Wear personal protective equipment like safety shoes, safety gloves, and insulating gloves during electrical connections.
- All electrical connections should be performed by qualified professionals.
- Cable colors in this document are for reference only. The cable specifications shall meet local laws and regulations.
- The inverter must be licensed by the electricity authority of the country/region in which it is located before it can be connected to the grid.

#### Cable specification requirements

$S_{PE}$  is the cross-sectional area of the PE cable, and S is the cross-sectional area of the AC cable.

No.	Cable	Type		Cable Specification	
				Outside Diameter (mm)	Conductor Cross Sectional Area(mm <sup>2</sup> )
1	DC cable	PV cable that meets 1500V standard.		4.7-6.4 or 6.4-8.4 (optional)	4-6
2	AC cable	Multi-core outdoor copper or aluminum cable <sup>[1]</sup>	For inverters with single row of AC terminals	35-75	<ul style="list-style-type: none"> <li>• Copper cable: <math>70 \leq S \leq 400</math></li> <li>• Aluminum cable: <math>150 \leq S \leq 400</math></li> <li>• <math>S_{PE} \geq S/2</math></li> </ul>
			For inverters with double rows of AC terminals	48.5-53	<ul style="list-style-type: none"> <li>• Copper cable: <math>70 \leq S \leq 400</math></li> <li>• Aluminum cable: <math>150 \leq S \leq 400</math></li> <li>• <math>S_{PE} \geq S/2</math></li> </ul>
		Single-core outdoor copper or aluminum cable <sup>[1]</sup>		<ul style="list-style-type: none"> <li>• Single core cable: 20-38</li> <li>• PE cable: 16-28</li> </ul>	<ul style="list-style-type: none"> <li>• Copper cable: <math>70 \leq S \leq 400</math></li> <li>• Aluminum cable: <math>150 \leq S \leq 400</math></li> <li>• <math>S_{PE} \geq S/2</math></li> </ul>

3	PE cable	Outdoors Cable	-	$S_{PE} \geq S/2$
4	RS485 communication cable	Outdoor shielded twisted pair cable that meets local requirements. <sup>[2]</sup>	8-11	-

Note

[1] A copper to aluminum wiring terminal is required when using an aluminum cable.

[2] Cable length of the RS485 communication cable:  $\leq 1000m$ .

The values in this table are valid only if the external protective earthing conductor and the phase conductors are the same material. Otherwise, the cross-sectional area of the external protective earthing conductor is to be determined in a manner which produces a conductance equivalent to that which results from the application of this table.

Dimension requirements for the copper to aluminum wiring terminal:

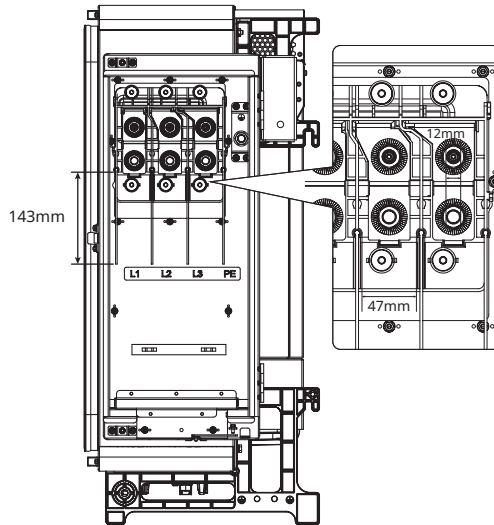

Prepare the copper to aluminum wiring terminal referring to the dimension requirements above. Contact the after-sales service for the copper to aluminum wiring terminal for AC cable with a cross sectional area of 400mm<sup>2</sup>.

## 6.2 Connecting the PE cable

### ⚠ WARNING

- The grounding points on the enclosure are preferred.
- Make sure that all the grounding points on the enclosure are equipotential connected when there are multiple inverters.
- To improve the corrosion resistance of the terminal, you are recommended to apply silica gel or paint on the ground terminal after installing the PE cable.
- The PE cable should be prepared by the customer.
- The M8 OT terminal should be prepared by customers.

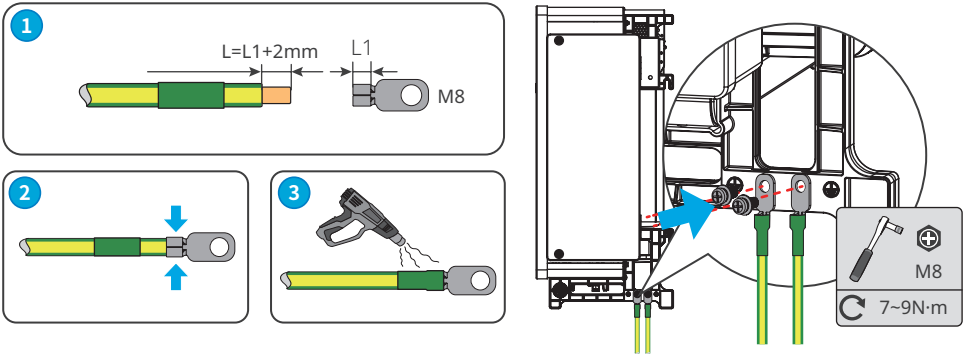

## 6.3 Connecting the PV Input Cable

### ⚠ DANGER

1. Confirm the following information before connecting the PV string to the inverter. Otherwise, the inverter may be damaged permanently or even cause fire and cause personal and property losses.
  - Make sure that sum of the max short circuit current of the strings per MPPT are within the permissible range, and the max input voltage is within the permissible range.
  - Make sure that the positive pole of the PV string connects to the PV+ of the inverter. And the negative pole of the PV string connects to the PV- of the inverter.
2. Do not plug or unplug the connectors when the equipment is working.

### ⚠ WARNING

1. Connect the DC cables using the delivered PV connectors. The manufacturer shall not be liable for the damage if other connectors are used.
2. The PV strings cannot be grounded. Ensure the minimum isolation resistance of the PV string to the ground meets the minimum isolation resistance requirements before connecting the PV string to the inverter.
3. The DC cable should be prepared by the customer.



**NOTICE**

- Multiple PV inputs can be connected to the inverter, each PV input is configured with a Maximum Power Point Tracker (MPPT).
- The two input strings per MPPT should be of the same type, the same number of modules, the same tilt and angle to ensure the best efficiency.
- The input strings in different MPPTs may differ from each other, like different number of modules and different tilt and angle.
- Measure the DC voltage using a 1500V multimeter. If the voltage is less than 0, check the polarity of the input cables. If the voltage is greater than 1500V, check the number of the PV modules, and remove some modules.
- Seal the PV input terminals using waterproof covers when they are not to be used. Otherwise, the ingress protection rating will be influenced.

**Connecting the DC Input Cable**

**Step 1** Prepare the DC input cable.

**Step 2** Crimp the crimp contacts.

**Step 3** Disassemble the PV connectors.

**Step 4** Route the DC cable and assemble the PV connectors. Detect the DC input voltage.

**Step 5** Plug the PV connectors into the PV terminals.

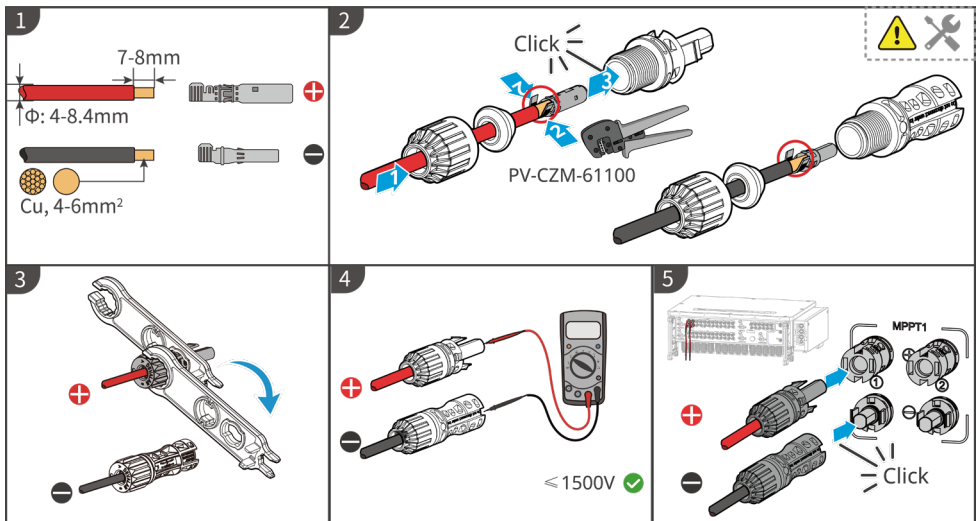
**MC4 PV connector**

## 6.4 Connecting the AC Output Cable

### WARNING

Do not connect loads between the inverter and the AC breaker directly connected to the inverter.

An AC circuit breaker should be installed on the AC side to make sure that the inverter can safely disconnect the grid when an exception happens. Select the appropriate AC circuit breaker in compliance with local laws and regulations. Recommended AC circuit breakers:

Inverter model	AC circuit breaker
GW250KH-UT, GW320K-UT, GW320KH-UT, GW320KH-UT-KR, GW350K-UT, GW350KH-UT	400A

### NOTICE

Install one AC circuit breaker for each inverter. Multiple inverters cannot share one AC circuit breaker.

### WARNING

- Pay attention to the silkscreens L1, L2, L3, and PE on the AC terminal. Connect the AC cables to the corresponding terminals. The inverter may be damaged if the cables are connected inappropriately.
- The grounding point inside the wiring box is used for connecting the PE cable of the multi core AC cable.
- Make sure that the whole cable cores are inserted into the AC terminals. No part of the cable core can be exposed.
- Make sure that the cables are connected securely. Otherwise, the terminal may be too hot to damage the inverter when the inverter is working.
- Reserve certain length of PE cable. Make ensure that the PE cable is the last one to bear the stress when the AC output cable is under tension.
- The waterproof rubber seal ring for the AC outlet hole is delivered with the inverter, which is located in the AC wiring box of the inverter. Please select the rubber seal ring types according to the actual using cables' specification.
- The M12 OT terminal for PE cable and AC cable should be prepared by customer.
- When multiple inverters are connected to the utility grid in parallel, up to 14 inverters can be connected to a single winding of the box transformer.

### Opening the AC wiring box

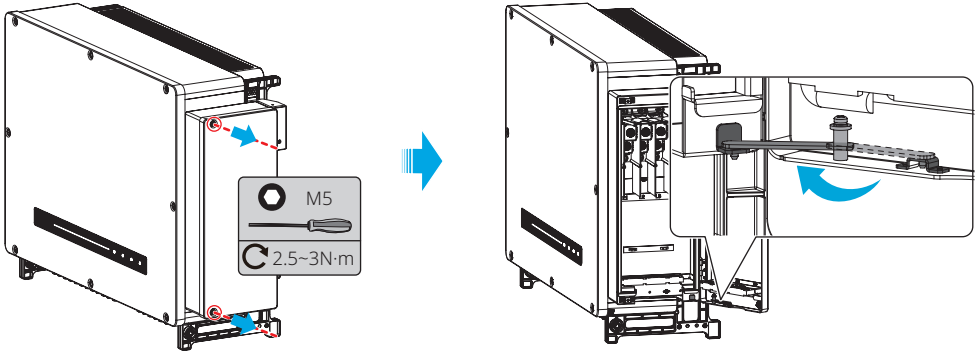

#### NOTICE

Keep the wiring box door open using the attached limit rod during wiring process.

### Connecting the AC output cable

**Step 1** Prepare the AC output cable and crimp the OT terminals.

**Step 2** Cut the rubber seal ring to a proper size.

**Step 3** Open the wiring box door and fix the cable conductors the corresponding terminals.

**Step 4** Fix the AC cable using the cable tie.

- Connect the multi-core copper cable to a single row of terminals as below:
- Take the three-core copper cable as an example.

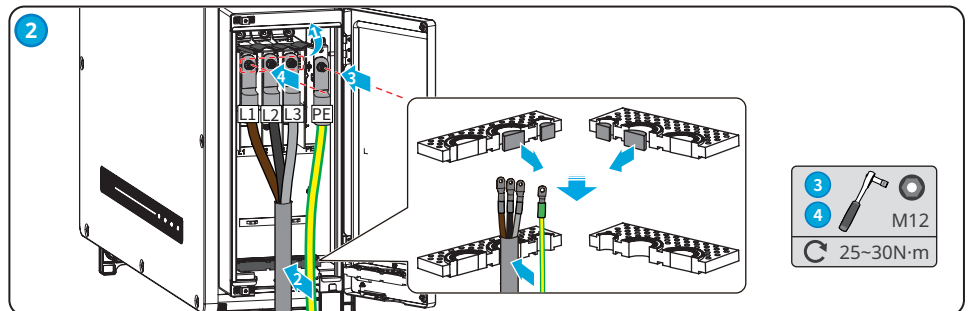
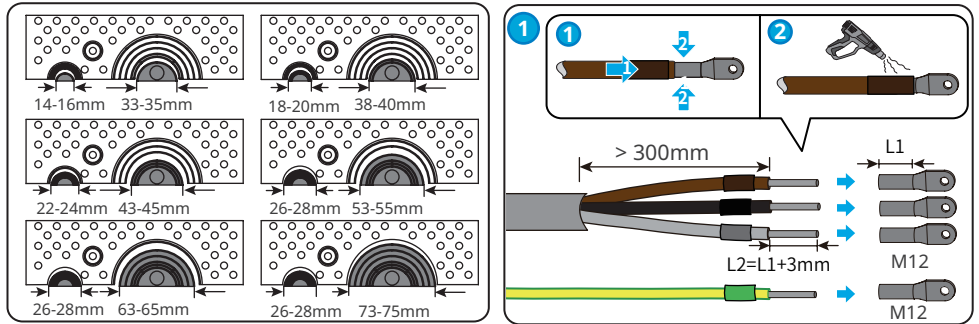

- Connect the multi-core copper cable to two rows of terminals as below:
- Take the three-core copper cable as an example.

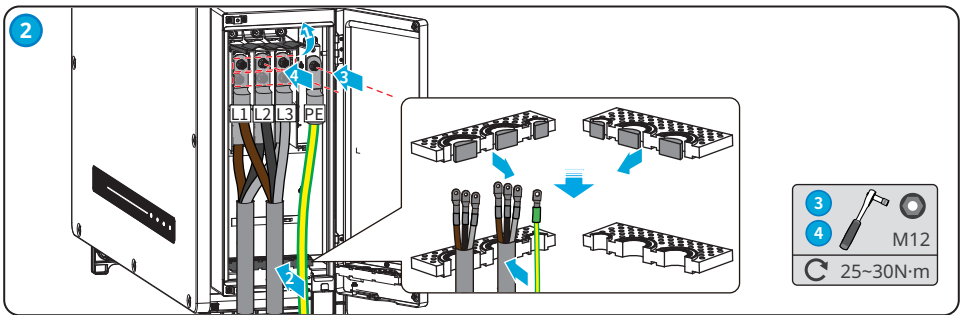
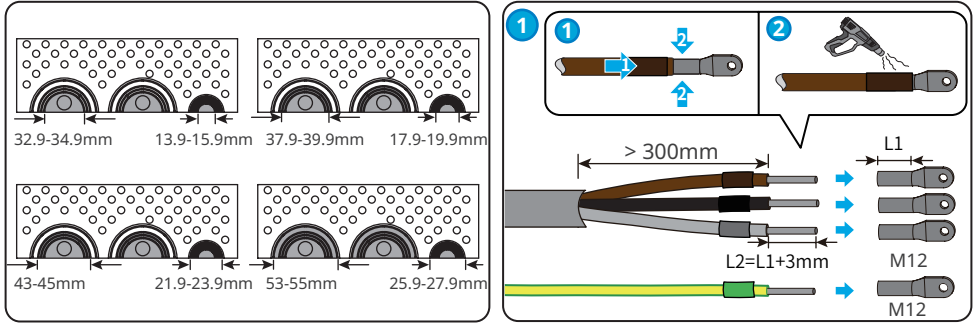

- Connect the single-core copper cable to the terminal:

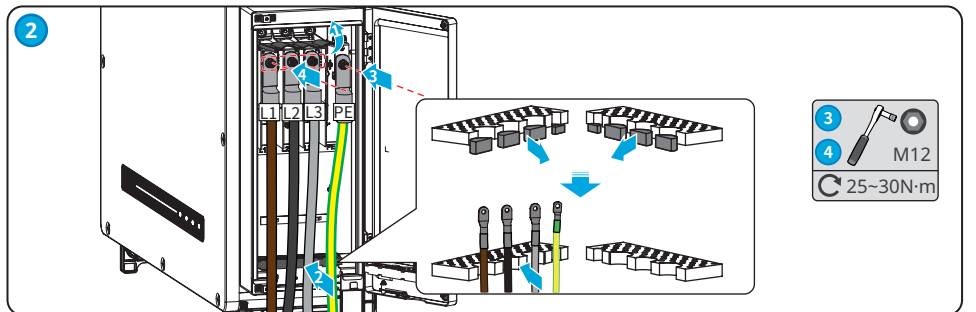
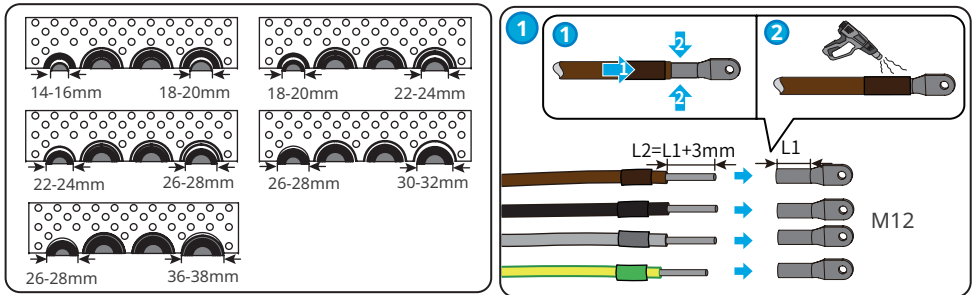

**NOTICE**

- Check whether the wiring is correct and firm after the connection. Clean the objects left within the maintaining cavity.
- Close the wiring box door to ensure the ingress protection rating.

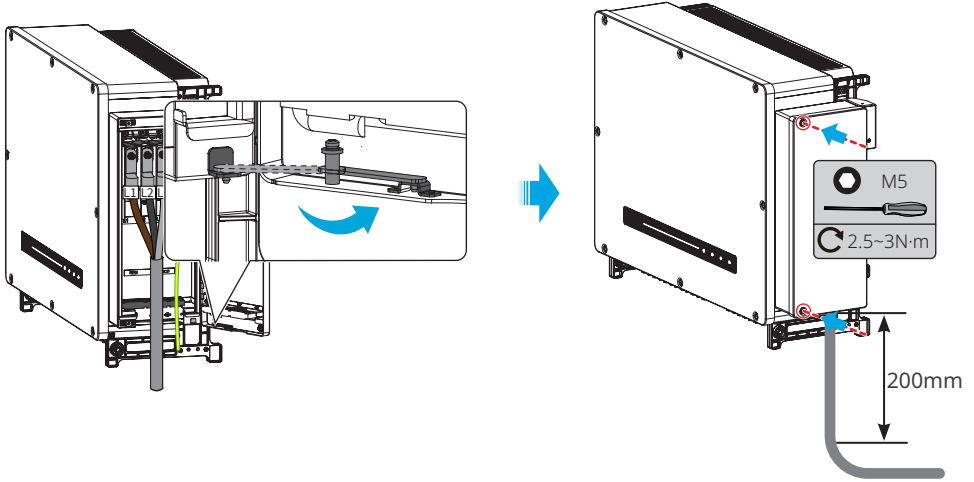
**Close the wiring box door**

## 6.5 Communication Connection

### 6.5.1 Connecting RS485 Communication Cable

#### NOTICE

- Make sure that the communication device is connected to the right COM port. Route the communication cable far away from any interference source or power cable to prevent the signal from being influenced.
- Connect the RS485 port of the inverter to other inverters, smart communication unit, or smart datalogger. The total length of the connection cable is less than 1000m.
- If more than 2 inverters are connected and also connected to the smart communication unit or datalogger, at most 20 inverters are allowed on the daisy chain.

#### RS485 network scenario

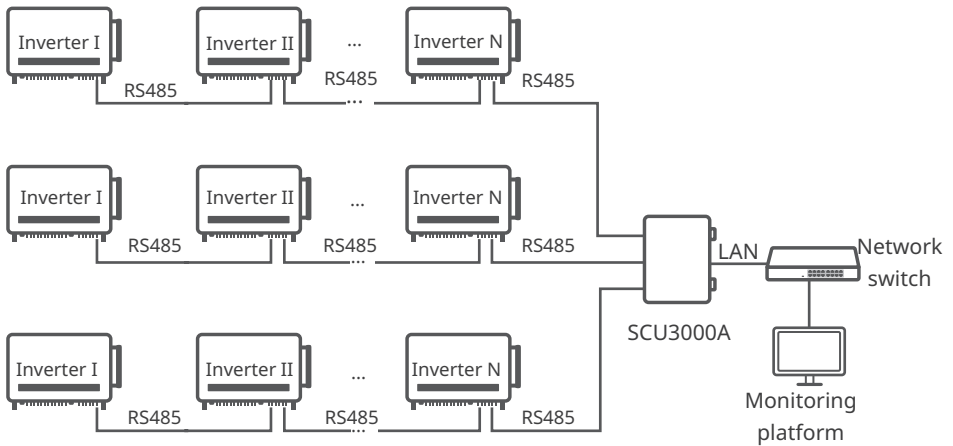

Communication Type	Terminal	Definition	Function
RS485	COM2	1:RS485_A1 2:RS485_B1 3:RS485_A1 4:RS485_B1 5: Grounding 6: Grounding	Connects to RS485 ports of other inverters or Smart Communication Unit.

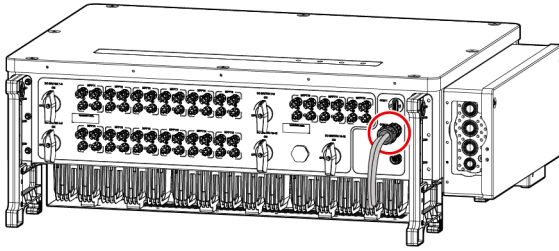

No.	COM2 (RS485)
1	RS485_A1
2	RS485_B1
3	RS485_A1
4	RS485_B1
5	Grounding
6	Grounding

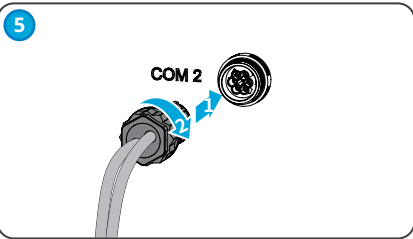
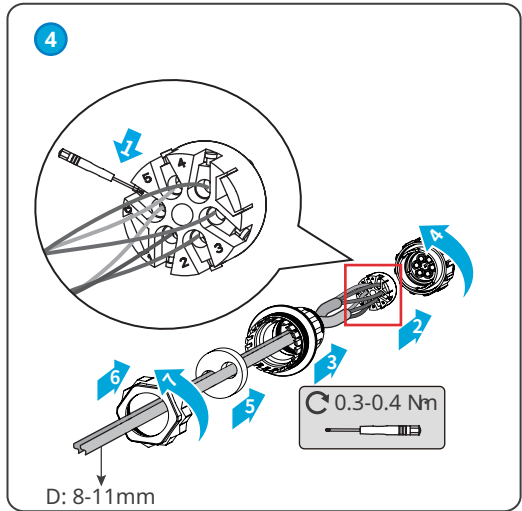
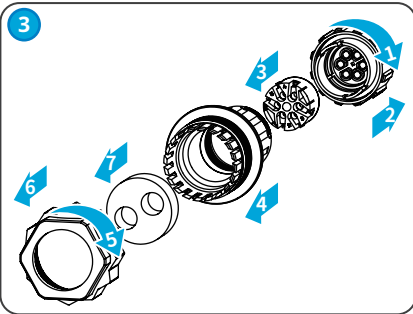
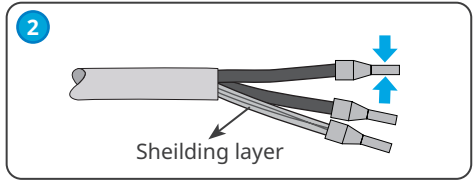
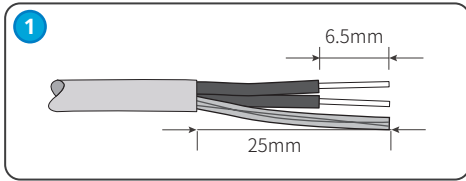

### Remote Shutdown or Emergency Power Off

Remote Shutdown: Europe only.

Emergency Power Off: India only.

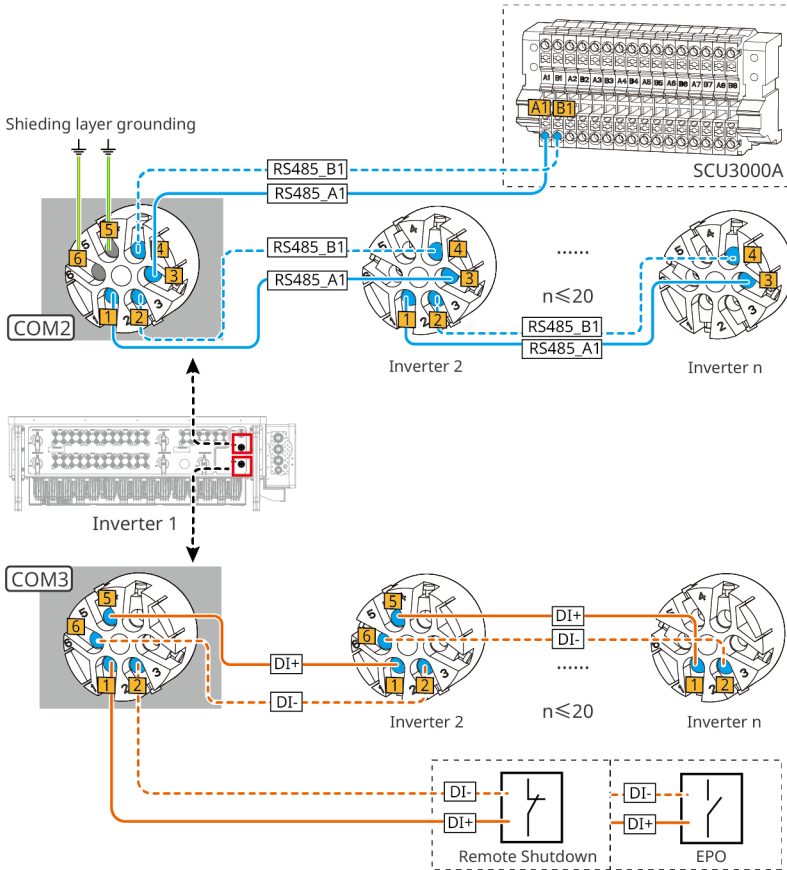

	COM Port	Port Definition	Function
Remote Shutdown or Emergency Power Off	COM3	1: DI1+ 2: DI1- 3: Reserved 4: Reserved 5: DI2+ 6: DI2-	Remote Shutdown: reserved to meet the safety regulations in Europe. Emergency Power Off: reserved to meet the safety regulations in India.

#### NOTICE

Connect the Remote Shutdown or Emergency Power Off cable using a 6PIN communication terminal as following.



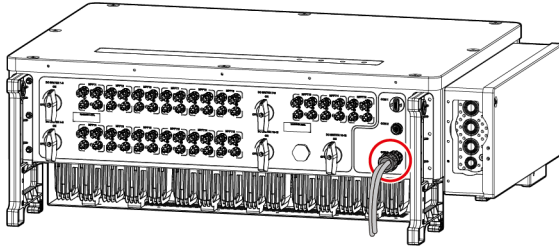

**1**

6.5mm  
25mm

**2**

**3**

**4**

0.3~0.4N·m

NO.	COM3
1	DI1+
2	DI1-
3	Reserved
4	Reserved
5	DI2+
6	DI2-

**5**

COM3

**NOTICE**

The COM3 communication port is installed with a short circuit wire. Remove the short circuit wire and keep it properly when enabling the function. Install the short circuit wire in PIN2 and PIN5 of the COM3 port when disabling the remote shutdown function.

### 6.5.2 Connecting PLC Communication Cable

A PLC communication module is integrated into the inverter to communicate with the smart datalogger or smart communication unit via the AC output cable. Refer to the user manual of the smart datalogger or communication unit for more detailed instructions.

Max communication distance between the inverter and the box-type transformer:

- The max distance is 1000m when multi-core AC cables are used.
- The max distance is 800m when single-core AC cables are used.

#### PLC network scenario

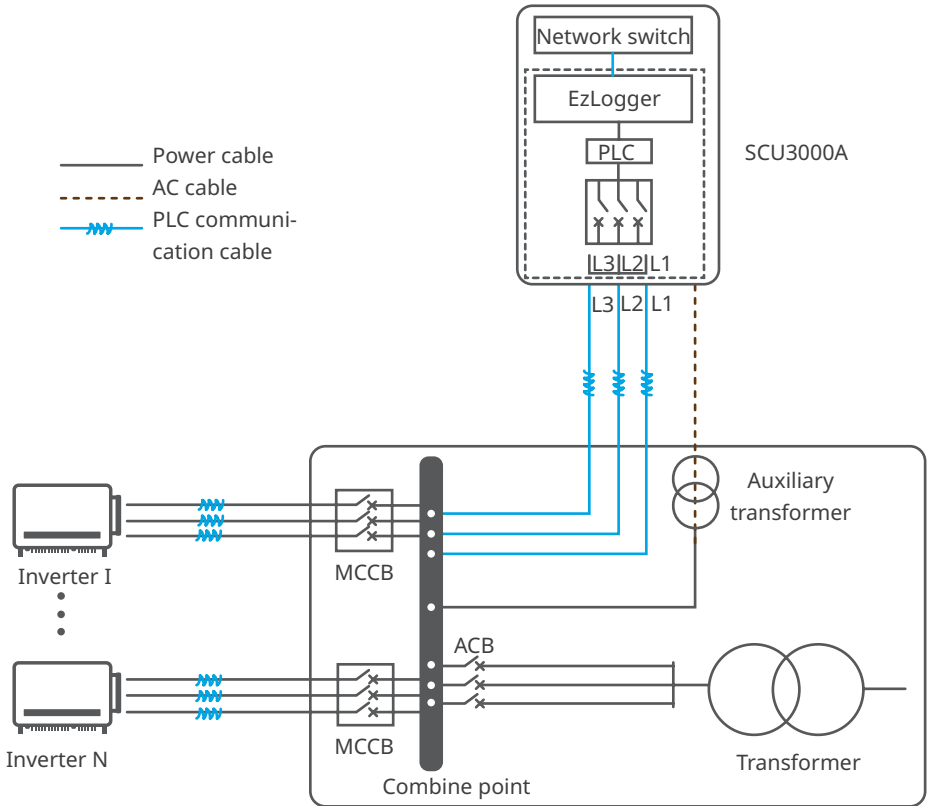

### 6.5.3 Installing the Communication Dongle (Optional)

Plug a bluetooth module into the inverter to establish a connection between the inverter and the smartphone or web pages. Set inverter parameters, check running information and fault information, and observe system status in time via the smartphone or web pages.

#### NOTICE

Refer to the delivered communication module user manual to get more introduction to the module. For more detailed information, visit [www.en.goodwe.com](http://www.en.goodwe.com).

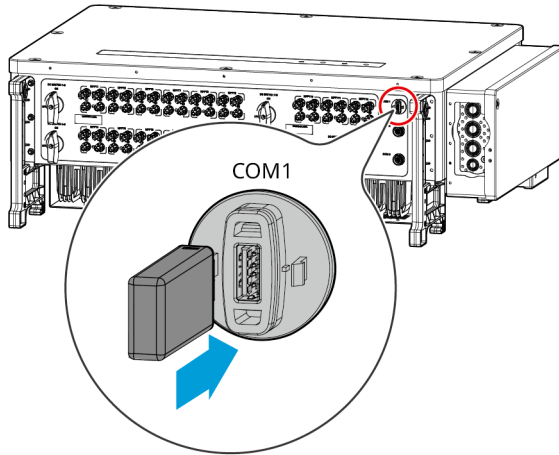

## 7 Equipment Commissioning

### 7.1 Check Before Power ON

No.	Check Item
1	The equipment is firmly installed at a clean place that is well-ventilated and easy-to-operate.
2	The PE, DC input, AC output, and communication cables are connected correctly and securely.
3	Cable ties are intact, routed properly and evenly.
4	Unused ports and terminals are sealed.
5	The voltage and frequency at the connection point meet the inverter grid connection requirements.

### 7.2 Power On

**Step 1** Turn on the AC breaker between the inverter and the utility grid.

**Step 2** Turn on the DC switch of the inverter.

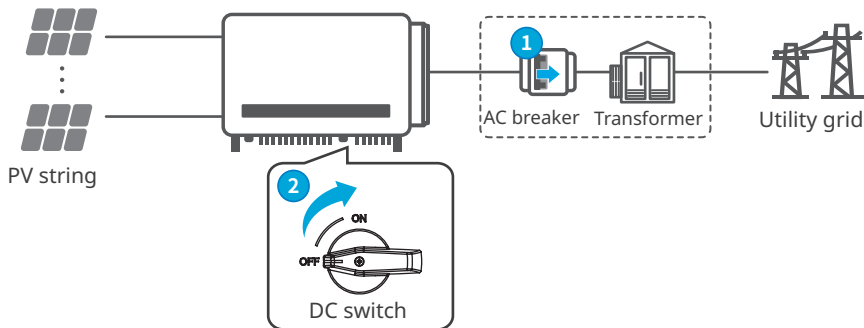

# 8 System Commissioning

## 8.1 Indicators and Buttons

Without LCD



With LCD

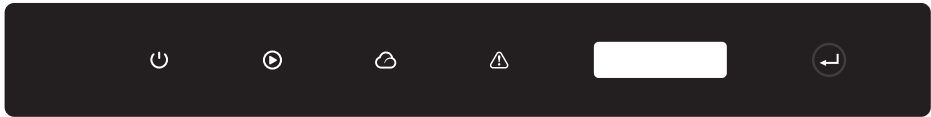

Indicator	Status	Description
⏻		ON= EQUIPMENT POWER ON
		OFF= EQUIPMENT POWER OFF
▶		ON= THE INVERTER IS FEEDING POWER
		OFF= THE INVERTER IS NOT FEEDING POWER
		SINGLE SLOW FLASH= SELF CHECK BEFORE CONNECTING TO THE GRID
		SINGLE FLASH = CONNECTING TO THE GRID
☁		ON= WIRELESS IS CONNECTED/ACTIVE
		BLINK 1 = WIRELESS SYSTEM IS RESETTING
		BLINK 2 = WIRELESS ROUTER PROBLEM
		BLINK 4 = WIRELESS SERVER PROBLEM
		BLINK = RS485 IS CONNECTED
		OFF= WIRELESS IS NOT ACTIVE
⚠		ON= A FAULT HAS OCCURRED
		OFF= NO FAULT

## 8.2 Setting Inverter Parameters via LCD

**NOTICE**

- The screenshots are for reference only. The actual interface may differ.
- The name, range, and default value of the parameters are subject to change or adjustment. The actual display prevails.
- The power parameters should be set by professionals. To prevent the generating capacity from being influenced by wrong parameters.

**LCD Button Description**

- Stop pressing the button for a period on any page, the LCD will get dark and go back to the initial page.
- Short press the button to switch menu or adjust parameter values.
- Long press the button to enter the submenu. After adjusting the parameter values, long press to set it.

Examples:

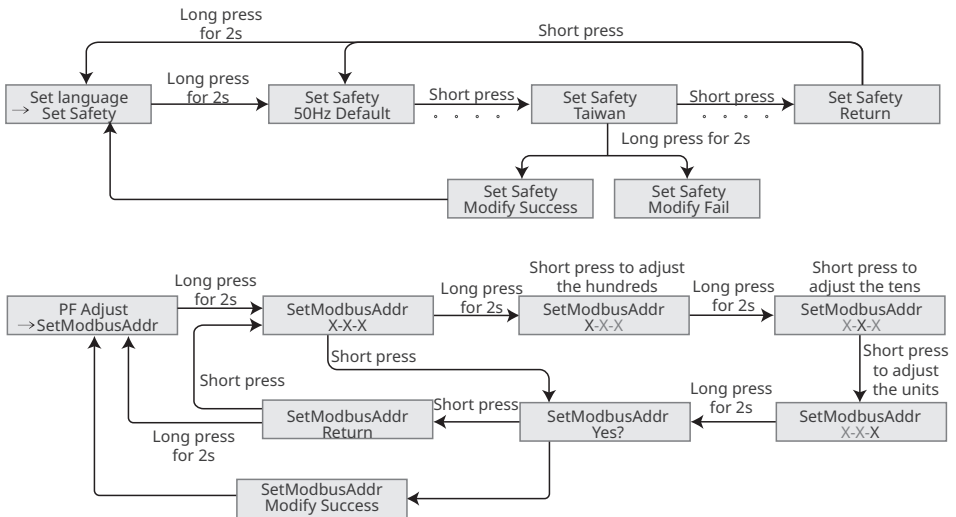

## LCD Menu Introduction

This part describes the menu structure, allowing you to view inverter information and set parameters more conveniently.

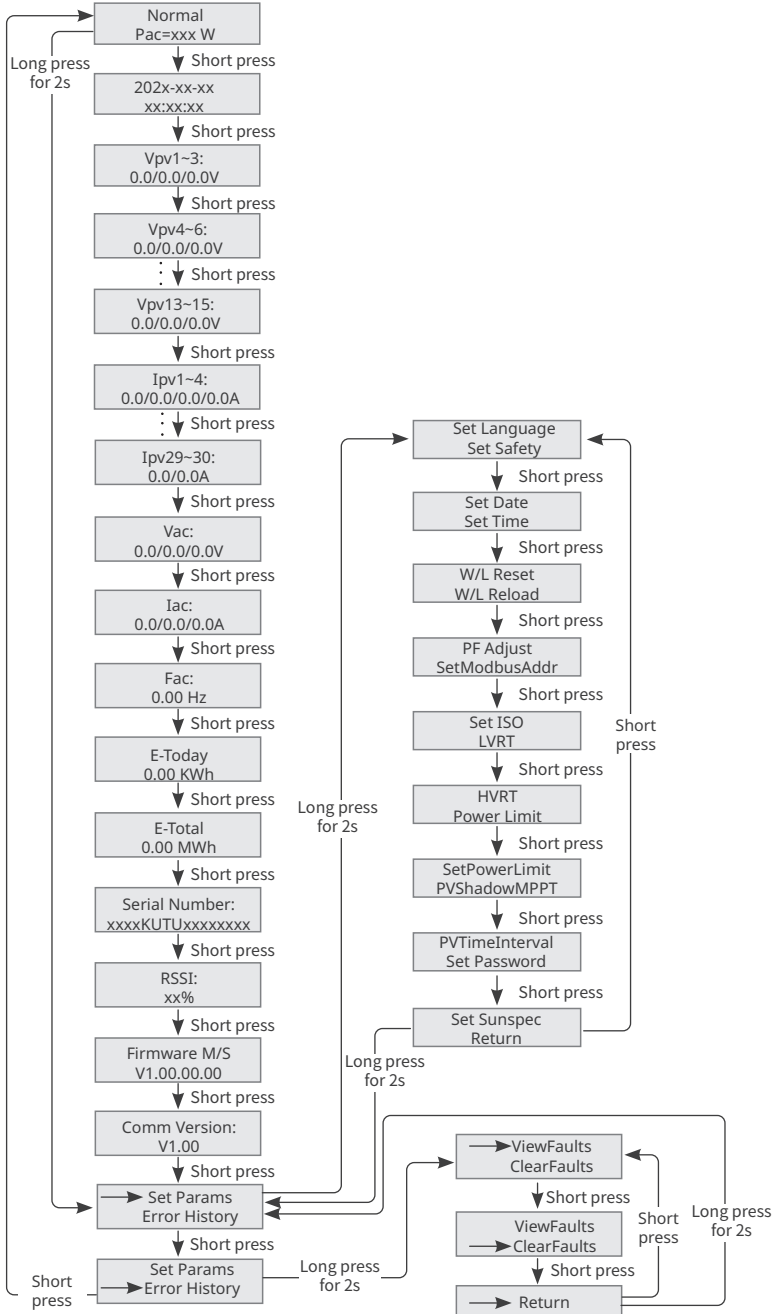

### 8.3 Setting Inverter Parameters via App

SolarGo App is one smart phone application used to communicate with the inverter via bluetooth, WiFi, 4G or GPRS modules. Commonly used functions are as follows:

1. Check the operating data, software version, alarms, etc.
2. Set grid parameters, communication parameters, etc.
3. Equipment maintenance.

For more details, refer to SolarGo User Manual. Scan the QR code or visit [SolarGo User Manual](#) to get the user manual.



SolarGo App



SolarGo App  
User Manual

### 8.4 Monitoring via SEMS Portal

SEMS Portal is a monitoring platform used to communicate with the inverter via WiFi, LAN, 4G, or GPRS. Commonly used functions:

1. Manage the organization or User information;
2. Add and monitor the power plant information;
3. Equipment maintenance.



SEMS Portal App



SEMS Portal App  
User Manual



## 9 Maintenance

### 9.1 Power OFF the Inverter

#### DANGER

- Power off the inverter before operations and maintenance. Otherwise, the inverter may be damaged or electric shocks may occur.
- Delayed discharge. Wait until the components are discharged after power off.

**Step 1** Issue a command to the inverter for disconnecting the grid via monitoring platform such as SolarGo app.

**Step 2** Turn off the AC breaker between the inverter and the utility grid.

**Step 3** Turn off the DC switch of the inverter.

### 9.2 Removing the Inverter

#### WARNING

- Make sure that the inverter is powered off.
- Wear proper PPE before any operations.

**Step 1** Disconnect all the cables, including DC input cables, AC output cables, communication cables, the communication module, and PE cables.

**Step 2** Remove the inverter from the mounting plate.

**Step 3** Remove the mounting plate.

**Step 4** Store the inverter properly. If the inverter needs to be used later, ensure that the storage conditions meet the requirements.

### 9.3 Disposing of the Inverter

If the inverter cannot work anymore, dispose of it according to the local disposal requirements for electrical equipment waste. The inverter cannot be disposed of together with household waste.

## 9.4 Troubleshooting

Perform troubleshooting according to the following methods. Contact the after-sales service if these methods do not work.

Collect the information below before contacting the after-sales service, so that the problems can be solved quickly.

1. Inverter information like serial number, software version, installation date, fault time, fault frequency, etc.
2. Installation environment, including weather conditions, whether the PV modules are sheltered or shadowed, etc. It is recommended to provide some photos and videos to assist in analyzing the problem.
3. Utility grid situation.

No.	Fault	Cause	Solutions
1	SPI Comm Fail	<ol style="list-style-type: none"> <li>1. The chip is not powered on.</li> <li>2. The program version of the chip is wrong.</li> </ol>	Disconnect the AC output switch and DC input switch, then connect them 5 minutes later. Contact the dealer or the after-sales service if the problem persists.
2	EEPROM Fail	The internal memory Flash is abnormal.	
3	Fac Fail	The utility grid frequency is out of the allowed range.	<ol style="list-style-type: none"> <li>1. If the problem occurs occasionally, the utility grid may be abnormal temporarily. The inverter will recover automatically after detecting that the utility grid is normal.</li> <li>2. If the problem occurs frequently, check whether the grid frequency is within the permissible range.               <ul style="list-style-type: none"> <li>• Contact the local power company if the grid frequency exceeds the permissible range.</li> <li>• Contact the dealer or the after-sales service if the grid frequency is within the permissible range.</li> </ul> </li> </ol>
4	DC-SPD	The inverter is struck by lightning.	<ol style="list-style-type: none"> <li>1. The inverter is struck by lightning.</li> <li>2. Disconnect the AC output switch and DC input switch, then connect them 5 minutes later. Contact the dealer or the after-sales service if the problem persists.</li> </ol>

No.	Fault	Cause	Solutions
5	Night DCSPS Fault	<ol style="list-style-type: none"> <li>1. Temporary abnormality caused by environmental factors.</li> <li>2. Internal components of the inverter are damaged.</li> </ol>	<p>Disconnect the AC output switch and DC input switch, then connect them 5 minutes later. Contact the dealer or the after-sales service if the problem persists.</p>
6	Relay Fail	<ol style="list-style-type: none"> <li>1. The relay is abnormal or short-circuited.</li> <li>2. The control circuit is abnormal.</li> <li>3. The AC cable connection is abnormal, like a virtual connection or short circuit.</li> </ol>	
7	BUS-start Fail	<ol style="list-style-type: none"> <li>1. The output power of the PV string is too low.</li> <li>2. The control circuit is abnormal.</li> </ol>	
8	PV Reverse Fault	The PV string is connected reversely.	Check whether the PV strings are connected reversely.
9	Night BUS Fault	<ol style="list-style-type: none"> <li>1. Utility grid power fails.</li> <li>2. The AC cable is disconnected, or the AC breaker is off.</li> </ol>	<p>Disconnect the AC output switch and DC input switch, then connect them 5 minutes later. Contact the dealer or the after-sales service if the problem persists.</p>
10	CPLD Error	<ol style="list-style-type: none"> <li>1. Temporary abnormality caused by environmental factors.</li> <li>2. Internal components of the inverter are damaged.</li> </ol>	<p>Disconnect the AC output switch and DC input switch, then connect them 5 minutes later. Contact the dealer or the after-sales service if the problem persists.</p>
11	DCI High	The equipment detects that the DC component of the internal output current exceeds the normal range.	Contact your dealer or after-sales service.

No.	Fault	Cause	Solutions
12	ISO Fail	<ol style="list-style-type: none"> <li>1. The PV string is short-circuited to the ground.</li> <li>2. The PV system is in a moist environment and the circuit is not well insulated to the ground.</li> </ol>	<ol style="list-style-type: none"> <li>1. Check whether the PV input cables are broken.</li> <li>2. Check whether the module frames and the metal bracket are securely grounded.</li> <li>3. Check whether the AC side is properly grounded.</li> </ol>
13	Vac Failure	The utility grid voltage is out of the allowed range.	<ol style="list-style-type: none"> <li>1. Check whether the AC output voltage of the inverter meets the grid requirements.</li> <li>2. Make sure that the phase sequence of the AC cables are connected correctly, and the PE cable is connected properly and firmly.</li> </ol>
14	ExFan Failure	<ol style="list-style-type: none"> <li>1. The fan power supply is abnormal.</li> <li>2. Mechanical exception.</li> <li>3. The fan is aging and damaged.</li> </ol>	<p>Disconnect the AC output switch and DC input switch, then connect them 5 minutes later. Contact the dealer or the after-sales service if the problem persists.</p>
15	GFCI Chk Fail	The sampling of the GFCI HCT is abnormal.	
16	AFCI Fault	<ol style="list-style-type: none"> <li>1. The PV string terminal is not firmly connected.</li> <li>2. The DC cable is broken.</li> </ol>	Please check whether the wiring of the PV modules are correct according to the requirements in the user manual.
17	Over Temperature	<ol style="list-style-type: none"> <li>1. The inverter is installed in a place with poor ventilation.</li> <li>2. The ambient temperature exceeds 60°C.</li> <li>3. A fault occurs in the internal fan of the inverter.</li> </ol>	<ol style="list-style-type: none"> <li>1. Check the ventilation and the ambient temperature at the installation point.</li> <li>2. If the ventilation is poor or the ambient temperature is too high, improve the ventilation and heat dissipation.</li> <li>3. Contact the dealer or after-sales service if both the ventilation and the ambient temperature are proper.</li> </ol>
18	InFan Fail	<ol style="list-style-type: none"> <li>1. The fan power supply is abnormal.</li> <li>2. Mechanical exception.</li> <li>3. The fan is aging and damaged.</li> </ol>	<p>Disconnect the AC output switch and DC input switch, then connect them 5 minutes later. Contact the dealer or the after-sales service if the problem persists.</p>

No.	Fault	Cause	Solutions
19	Gnd I Fail	The input insulation resistance value to the ground decreases when the inverter is operating.	<ol style="list-style-type: none"> <li>1. Check whether the working environment of the inverter meets the requirements. For example, the fault may be occurred due to high humidity in rainy days.</li> <li>2. Make sure that the components are properly grounded and the AC side is properly grounded.</li> </ol>
20	Utility Loss	<ol style="list-style-type: none"> <li>1. Utility grid power fails.</li> <li>2. The AC cable is disconnected or the AC breaker is off.</li> </ol>	<ol style="list-style-type: none"> <li>1. The alarm is automatically cleared after the grid power supply is restored.</li> <li>2. Check whether the AC cable is connected and the AC breaker is on.</li> </ol>
21	AC HCT Fail	The HCT sensor is abnormal.	<p>Disconnect the AC output switch and DC input switch, then connect them 5 minutes later. Contact the dealer or the after-sales service if the problem persists.</p>
22	Relay Fault	<ol style="list-style-type: none"> <li>1. The relay is abnormal or short-circuited.</li> <li>2. The sampling circuit of the relay is abnormal.</li> </ol>	
23	GFCI Chk Fail	The sampling of the GFCI HCT is abnormal.	
24	SPD Fail	The inverter is struck by lightning.	<ol style="list-style-type: none"> <li>1. Improve the lightning protection facilities around the inverter.</li> <li>2. Disconnect the AC output switch and DC input switch, then connect them 5 minutes later. Contact the dealer or the after-sales service if the problem persists.</li> </ol>
25	DC Switch Fail	The tripping times of the DC trip switch exceeds the limit.	Contact the dealer or after-sales service.
26	Ref-V Chk Fail	The reference circuit fails.	Disconnect the AC output switch and DC input switch, then connect them 5 minutes later.
27	HCT Chk Fail	The AC sensor is abnormal in sampling.	Contact the dealer or the after-sales service if the problem persists.
28	PID Error	<ol style="list-style-type: none"> <li>1. Abnormal Ground</li> <li>2. The PID module is abnormal.</li> </ol>	<ol style="list-style-type: none"> <li>1. Check whether the DC wirings and AC wirings are abnormal.</li> <li>2. Check whether the PID module is abnormal</li> <li>3. Contact your dealer or after-sales service.</li> </ol>

No.	Fault	Cause	Solutions
29	PV Over Curr	<ol style="list-style-type: none"> <li>1. The PV module configuration is not proper.</li> <li>2. The hardware is damaged.</li> </ol>	<p>Disconnect the AC output switch and DC input switch, then connect them 5 minutes later.</p> <p>Contact the dealer or the after-sales service if the problem persists.</p>
30	Model Error	<ol style="list-style-type: none"> <li>1. Temporary abnormality caused by environmental factors.</li> <li>2. Internal components of the inverter are damaged.</li> </ol>	
31	PV Short Failure	The hardware is abnormal.	Contact your dealer or after-sales service.
32	BUS-start Fail	<ol style="list-style-type: none"> <li>1. The output power of the PV string is too low.</li> <li>2. The control circuit is abnormal.</li> </ol>	<p>Disconnect the AC output switch and DC input switch, then connect them 5 minutes later.</p> <p>Contact the dealer or the after-sales service if the problem persists.</p>
33	PV Over Voltage	Excess PV modules are connected in the series.	<ol style="list-style-type: none"> <li>1. Check whether the PV string input voltage consistent with the value displayed on the LCD.</li> <li>2. Check whether the PV string voltage meets the maximum input voltage requirements.</li> </ol>
34	PV Voltage Low	Sun light is weak or changing abnormally.	<ol style="list-style-type: none"> <li>1. If the problem occurs occasionally, the reason might be abnormal sun light. The inverter will recover automatically without manual intervention.</li> <li>2. If the problem occurs frequently, contact the dealer or the after-sales service.</li> </ol>

No.	Fault	Cause	Solutions
35	PV HCT Fail	<ol style="list-style-type: none"> <li>1. Temporary abnormality caused by environmental factors.</li> <li>2. Internal components of the inverter are damaged.</li> </ol>	<p>Disconnect the AC output switch and DC input switch, then connect them 5 minutes later. Contact the dealer or the after-sales service if the problem persists.</p>
36	PV Over Curr	<ol style="list-style-type: none"> <li>1. Temporary abnormality caused by environmental factors.</li> <li>2. Internal components of the inverter are damaged.</li> </ol>	
37	BUS Unbalance	<ol style="list-style-type: none"> <li>1. The sampling circuit of the relay is abnormal.</li> <li>2. Abnormal hardwares</li> </ol>	
38	DC Bus High	<ol style="list-style-type: none"> <li>1. The PV voltage is too high.</li> <li>2. The sampling of the inverter BUS voltage is abnormal.</li> </ol>	
39	PV Continuous Hardware Overcurrent	<ol style="list-style-type: none"> <li>1. The PV module configuration is not proper.</li> <li>2. The hardware is damaged.</li> </ol>	

## 9.5 Routine Maintenance



Power off the inverter before operations and maintenance. Otherwise, the inverter may be damaged or electric shocks may occur.

Maintaining Item	Maintaining Method	Maintaining Period
System Clean	Check the heat sink, air intake, and air outlet for foreign matter or dust.	Once 6-12 months
Fan	Check the fan for proper working status, low noise, and intact appearance.	Once a year
DC Switch	Turn the DC switch on and off ten consecutive times to make sure that it is working properly.	Once a year
Electrical Connection	Check whether the cables are securely connected. Check whether the cables are broken or whether there is any exposed copper core.	Once 6-12 months
Sealing	Check whether all the terminals and ports are properly sealed. Reseal the cable hole if it is not sealed or too big.	Once a year



## 10 Technical Parameters

Technical Parameters	GW320KH-UT	GW350KH-UT	GW320K-UT	GW350K-UT
<b>Input</b>				
Max. Input Power (kW)	576	576	576	576
Max. Input Voltage (V)	1500	1500	1500	1500
MPPT Operating Voltage Range (V)	480~1500	480~1500	480~1500	480~1500
MPPT Voltage Range at Nominal Power (V)	850~1300	850~1300	850~1300	850~1300
Start-up Voltage (V)	500	500	500	500
Nominal Input Voltage (V)	1160	1160	1160	1160
Max. Input Current per MPPT (A)	40	40	30	30
Max. Short Circuit Current per MPPT (A)	60	60	50	50
Max. Backfeed Current to The Array (A)	0	0	0	0
No. of MPP Trackers	12	12	15	15
No. of Input Strings per MPPT	2	2	2	2
<b>Output</b>				
Nominal Output Power (kW)	320	352	320	352
Nominal Output Apparent Power(kVA)	320	352	320	352
Max. AC Active Power (kW)	352	352	352	352
Max. AC Apparent Power (kVA)	352	352	352	352
Nominal Power at 40°C (kW)	320	352	320	352
Max. Power at 40°C (Including AC Overload) (kW)	352	352	352	352
Nominal Output Voltage (V)	800, 3L/PE	800, 3L/PE	800, 3L/PE	800, 3L/PE
Output Voltage Range (V)	640~920	640~920	640~920	640~920
Nominal AC Grid Frequency (Hz)	50 / 60	50 / 60	50 / 60	50 / 60
AC Grid Frequency Range (Hz)	45~55/55~65	45~55/55~65	45~55/55~65	45~55/55~65
Max. Output Current (A)	254	254	254	254
Max. Output Fault Current (Peak and Duration) (A)	500@3μs	500@3μs	500@3μs	500@3μs
Inrush Current (Peak and Duration) (A)	500@3μs	500@3μs	500@3μs	500@3μs

Nominal Output Current (A)	231	254	231	254
Power Factor	~1 (Adjustable from 0.8 leading to 0.8 lagging)			
Max. Total Harmonic Distortion	<3%	<3%	<3%	<3%
Maximum Output Overcurrent Protection (A)	500	500	500	500
<b>Efficiency</b>				
Max. Efficiency	99.01%	99.01%	99.01%	99.01%
European Efficiency	98.8%	98.8%	98.8%	98.8%
CEC Efficiency	98.52%	98.52%	98.52%	98.52%
<b>Protection</b>				
PV String Current Monitoring	Integrated	Integrated	Integrated	Integrated
Internal Humidity Monitoring	Integrated	Integrated	Integrated	Integrated
PV Insulation Resistance Detection	Integrated	Integrated	Integrated	Integrated
Residual Current Monitoring Unit	Integrated	Integrated	Integrated	Integrated
PV Reverse Polarity Protection	Integrated	Integrated	Integrated	Integrated
Anti-islanding Protection	Integrated	Integrated	Integrated	Integrated
AC Overcurrent Protection	Integrated	Integrated	Integrated	Integrated
AC Short Circuit Protection	Integrated	Integrated	Integrated	Integrated
AC Overvoltage Protection	Integrated	Integrated	Integrated	Integrated
DC Switch	Integrated	Integrated	Integrated	Integrated
DC Surge Protection	Type II	Type II	Type II	Type II
AC Surge Protection	Type II	Type II	Type II	Type II
Emergency Power Off	Optional	Optional	Optional	Optional
Remote Shutdown	Optional	Optional	Optional	Optional
Anti-PID	Optional	Optional	Optional	Optional
PID Recovery	Optional	Optional	Optional	Optional
Reactive Power Compensation at Night	Optional	Optional	Optional	Optional
Power Supply at Night	Integrated	Integrated	Integrated	Integrated
I-V Curve Scan	Optional	Optional	Optional	Optional
<b>General Data</b>				
Operating Temperature Range (°C)	-35 ~ +60	-35 ~ +60	-35 ~ +60	-35 ~ +60
Derating Temperature (°C)	45	45	45	45
Storage Temperature	-40 ~ +70	-40 ~ +70	-40 ~ +70	-40 ~ +70
Relative Humidity	0~100%	0~100%	0~100%	0~100%
Max Operating Altitude (m)	5000(>4000 derating)			

Cooling Method	Smart Fan Cooling			
User Interface	LED,LCD (Optional), WLAN + APP			
Communication	RS485 or PLC			
Communication Protocols	Modbus RTU			
Weight (Kg)	124		126	
Dimensions (W×H×D mm)	1120*810*368			
Noise Emission (dB)	70			
Topology	Non-isolated			
Self-consumption at Night (W)	< 3			
Ingress Protection Rating	IP66			
Anti-corrosion Class	C4 (C5 Optional)			
DC Connector	MC4 (4~6mm <sup>2</sup> )			
AC Connector	OT/DT terminal (Max. 400 mm <sup>2</sup> )			
Environmental Category	4K4H			
Pollution Degree	III			
Overvoltage Category	DC II / AC III			
Protective Class	I			
The Decisive Voltage Class (DVC)	PV: C AC: C Com: A			
Active Anti-islanding Method	AFDPPF + AQDPPF			
Country of Manufacture	China	China	China	China

Technical Parameters	GW320KH-UT-KR	GW250KH-UT
<b>Input</b>		
Max. Input Power (kW)	576	450
Max. Input Voltage (V)	1500	1500
MPPT Operating Voltage Range (V)	480~1500	480~1500
MPPT Voltage Range at Nominal Power (V)	850~1300	850~1300
Start-up Voltage (V)	500	500
Nominal Input Voltage (V)	1160	1160
Max. Input Current per MPPT (A)	40	40
Max. Short Circuit Current per MPPT (A)	60	60
Max. Backfeed Current to The Array (A)	0	0
No. of MPP Trackers	12	12
No. of Input Strings per MPPT	2	2
<b>Output</b>		
Nominal Output Power (kW)	320	250
Nominal Output Apparent Power(kVA)	320	250
Max. AC Active Power (kW)	352	275
Max. AC Apparent Power (kVA)	352	275
Nominal Power at 40°C (kW)	320	250
Max. Power at 40°C (Including AC Overload) (kW)	352	275
Nominal Output Voltage (V)	800, 3L/PE	800, 3L/PE
Output Voltage Range (V)	720~880	640~920
Nominal AC Grid Frequency (Hz)	50 / 60	50 / 60
AC Grid Frequency Range (Hz)	45~55 / 55~65	45~55 / 55~65
Max. Output Current (A)	254	198.5
Max. Output Fault Current (Peak and Duration) (A)	500@3μs	500@3μs
Inrush Current (Peak and Duration) (A)	500@3μs	500@3μs
Nominal Output Current (A)	231	180.5
Output Power Factor	~1 (Adjustable from 0.8 leading to 0.8 lagging)	
Output THDi (@Nominal Output)	<3%	<3%
Maximum Output Overcurrent Protection (A)	500	500
<b>Efficiency</b>		
Max. Efficiency	99.01%	99.01%
European Efficiency	98.8%	98.8%

CEC Efficiency	98.52%	98.52%
<b>Protection</b>		
PV String Current Monitoring	Integrated	Integrated
Internal Humidity Monitoring	Integrated	Integrated
PV Insulation Resistance Detection	Integrated	Integrated
Residual Current Monitoring	Integrated	Integrated
PV Reverse Polarity Protection	Integrated	Integrated
Anti-islanding Protection	Integrated	Integrated
AC Overcurrent Protection	Integrated	Integrated
AC Short Circuit Protection	Integrated	Integrated
AC Overvoltage Protection	Integrated	Integrated
DC Switch	Integrated	Integrated
DC Surge Protection	Type II	Type II
AC Surge Protection	Type II	Type II
Emergency Power Off	Optional	Optional
Remote Shutdown	Optional	Optional
Anti-PID	Optional	Optional
Reactive Power Compensation at Night	Optional	Optional
Power Supply at Night	Integrated	Integrated
I-V Curve Scan	Optional	Optional
<b>General Data</b>		
Operating Temperature Range (°C)	-35 ~ +60	-35 ~ +60
Derating temperature (°C)	45	45
Storage Temperature (°C)	-40 ~ +70	-40 ~ +70
Relative Humidity	0 ~ 100%	0 ~ 100%
Max. Operating Altitude (m)	5000 (>4000 derating)	
Cooling Method	Smart Fan Cooling	
User Interface	LCD, WLAN+APP	LED, WLAN+APP
Communication	RS485 or PLC	
Communication Protocols	Modbus RTU	
Weight (kg)	124	124
Dimension (W×H×D mm)	1120*810*368, 1120*892*368 (installing fuse)	1120*810*368
Noise Emission (dB)	70	70

Topology	Non-isolated	
Self-consumption at Night (W)	< 30	< 3
Ingress Protection Rating	IP66	IP66
Anti-corrosion Class	C5	C4 (C5 Optional)
DC Connector	MC4 (4~6mm <sup>2</sup> )	
AC Connector	OT/DT terminal (Max. 400 mm <sup>2</sup> )	
Environmental Category	4K4H	4K4H
Pollution Degree	III	III
Overvoltage Category	DC II / AC III	DC II / AC III
Protective Class	I	I
The Decisive Voltage Class (DVC)	PV: C AC: C Com: A	
Active Anti-islanding Method	AFDPF + AQDPF	
Country of Manufacture	China	China



Official Website

**GoodWe Technologies Co.,Ltd.**

---

 No. 90 Zijin Rd., New District, Suzhou, 215011, China

 [www.goodwe.com](http://www.goodwe.com)

 [service@goodwe.com](mailto:service@goodwe.com)



Local Contacts