

Prefabricated MVS User Manual

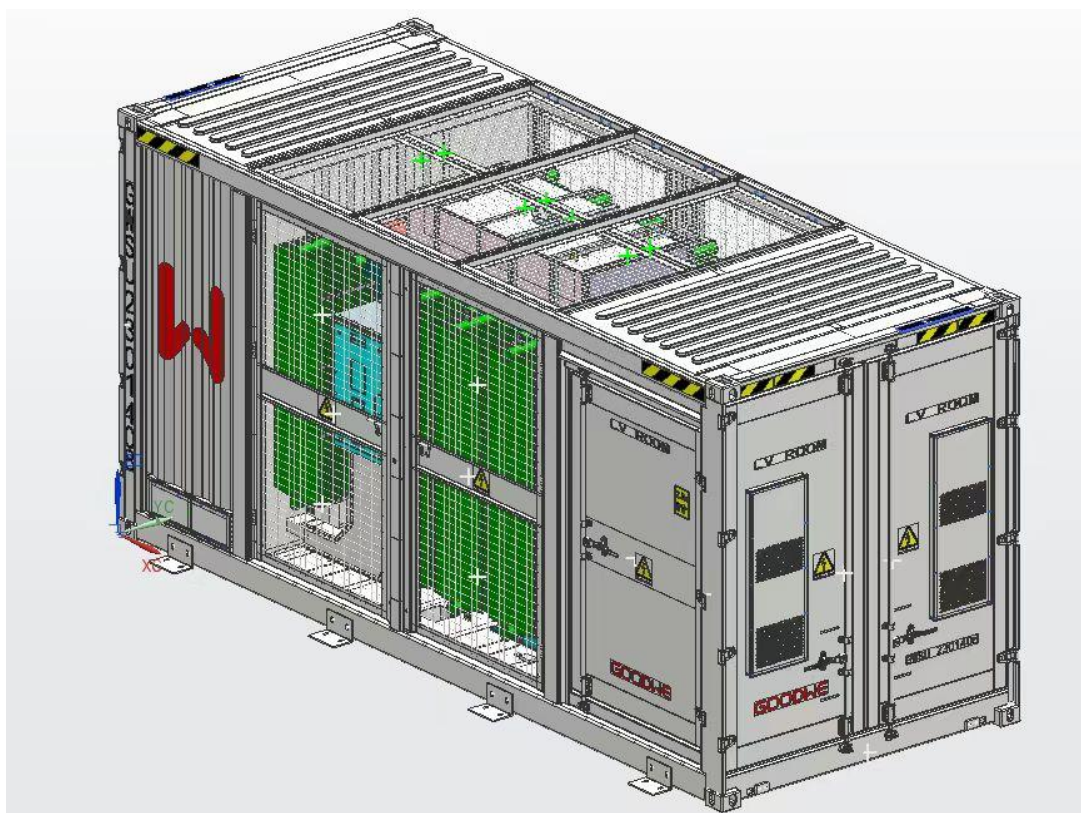

Catalog

1 About this manual	1
1.1 Applicable products	1
1.2 Model description	1
1.3 Applicable personnel	1
1.4 Manual use	2
1.5 Symbol usage	2
2 Safety instructions	4
2.1 General safety rules	4
2.2 Ground fault protection	5
2.3 Live measurement	5
2.4 Use of measuring equipment	6
2.5 Complete power-off operation	6
2.6 Static electricity protection	6
2.7 Body warning sign protection	7
2.8 Safety warning sign setting	7
2.9 Daily operation and maintenance	7
2.10 Other precautions	8
2.10.1 Manual storage	8
2.10.2 Product Scrap	8
2.10.3 Manual Instructions	9
3 Product Description	10
3.1 External design of the cabinet	10
3.1.1 View	10
3.1.2 Equipment composition	11
3.1.3 Mechanical Dimensions	12
3.1.4 Maximum door opening size	12
3.2 Internal design of the cabinet	13
3.2.1 Internal equipment composition	13
3.2.2 Bottom cable entry hole	13
3.2.3 Medium voltage cable entry hole	14

3.2.4	<i>Internal Devices</i>	14
3.2.5	<i>Low voltage cabinet</i>	14
3.2.6	<i>Transformer room</i>	17
3.2.7	<i>Medium voltage cabinet</i>	18
3.2.8	<i>Power distribution room</i>	19
4	Identify and store MVSs	21
4.1	Identifying MVSs	21
4.2	Check the integrity of transportation	21
4.3	Storage	22
5	Mechanical installation	23
5.1	Conditions of transportation	23
5.2	Lifting and transporting	24
5.2.1	<i>Precautions for lifting</i>	24
5.2.2	<i>Lifting</i>	25
5.2.3	<i>Fastening of connectors</i>	26
5.3	Building the foundation	27
5.3.1	<i>Selection of installation site</i>	27
5.3.2	<i>Recommended foundation scheme</i>	28
5.3.3	<i>Fixed MVS (optional)</i>	29
5.4	Installation check	30
5.5	Installation space requirements	30
5.6	Remove the film and box converter cover	31
6	Electrical connections	32
6.1	Safety Instructions	32
6.1.1	<i>General</i>	32
6.1.2	<i>The five security principles</i>	34
6.2	Wiring schematic diagram	35
6.3	Electrical connection	36
6.3.1	<i>Grounding</i>	36
6.3.2	<i>Low-voltage wiring</i>	38
6.3.3	<i>Medium voltage wiring</i>	43

6.3.4	<i>Communication wiring</i>	43
6.3.5	<i>Auxiliary power supply wiring</i>	43
6.4	Check after wiring is completed	43
7	Power transmission operation	45
7.1	Inspection before power transmission	45
7.1.1	<i>Cabinet inspection</i>	45
7.1.2	<i>Medium voltage ring network cabinet</i>	45
7.1.3	<i>Medium voltage transformer</i>	46
7.1.4	<i>Low voltage cabinet</i>	49
7.2	Power transmission steps	50
8	Troubleshooting	51
9	Routine maintenance	53
9.1	Safety Precautions	53
9.2	Maintenance	54
9.2.1	<i>Overview</i>	54
9.2.2	<i>Maintenance period</i>	54
9.3	Maintenance items	55
9.4	Transformer oil drain operation	58
9.5	Paint repair measures	59
10	Appendix	62
10.1	Technical data (reference data of the manual prototype, the specific parameters are subject to the agreement)	62
10.2	Tightening torques	68
10.3	Contact information	69

1 About this manual

1.1 Applicable products

This manual applies to the following models:

- GW7000K-MVS

For the [series MVS](#), the specific applicable product model shall be confirmed with Goodwe.

Unless otherwise specified below, the above products will be replaced by "MVS".

1.2 Model description

Model	Rated power	Connect the device
GW7000K-MVS	7000 kVA	28*800V GW250K-HT

The functions, appearance and wiring methods of the above models are the same, only the number of channels connected to the inverter is different. This manual takes GW7000K-MVS as an example, the step-up transformer in the [series MVS](#) is a double-split type oil immersed transformer, and briefly introduces the mechanical installation and electrical connection process.

1.3 Applicable personnel

This manual is applicable to personnel who transport, install and operate this product. Readers should at least meet the following requirements:

- Should have certain expertise in electronics, electrical wiring and machinery, and be familiar with electrical and mechanical schematics diagrams.
- Be familiar with the composition and working principle of photovoltaic grid-connected power generation system.
- Familiar with the composition and working principle of MVS and front and rear level equipment.
- Should have received professional training related to the installation and commissioning of electrical equipment.
- Should have the emergency response capability to the danger or emergency in the process of installation or commissioning.
- Should be familiar with the relevant standards and specifications of the country/region where the project is located, and must obtain the operation certificate of the relevant standards and specifications of the country/region where the project is located.
- Should be familiar with what is described in this manual.

1.4 Manual use

Please read this manual carefully before transporting and installing this product. The operation can only be carried out after the contents of the manual are clearly understood. Please keep this manual and other information in the product components together so that the relevant personnel can get it at any time.

- Medium voltage ring network cabinet manual
- MV transformer manual
- Other accompanying manuals

The contents of the manual and the pictures, logos, symbols, etc. used are all owned by GoodWe. Persons who are not inside our company are not allowed to publicly reproduce all or part of the content without written authorization.

1.5 Symbol usage

In order to ensure the user's personal and property safety when installing this product, or to use this product efficiently and optimally, relevant information is provided in the manual and highlighted with appropriate symbols.

The following lists the symbols that may be used in this manual, please read carefully for better use of this manual.



Danger

"Danger" means there is a high potential danger, if not avoided, it will lead to serious accidents such as casualties.



Danger

"Warning" means there is a moderate potential danger, if not avoided, it may lead to serious accidents such as personal injury or death.



Caution

"CAUTION" indicates a low potential danger, if not avoided, could result in moderate or minor personal injury.

Caution

"CAUTION" indicates a potential risk, if not avoided, could result in improper operation of the equipment or property damage.



"Instructions" are additional information in the manual, emphasizing and supplementing the content, and may also provide optimal use of the product.

Please always pay attention to the danger warning signs on the body, including:

Identification

Identification Definition



This symbol indicates that there is a high voltage inside the body, and touching it may cause an electric shock hazard.



This symbol indicates that this is the protective earth (PE) terminal, Which needs to be firmly grounded to ensure operator safety.

2 Safety instructions

All safety instructions in this manual must be strictly followed at all times. In order to avoid possible casualties and property losses during installation or operation, and to effectively extend the service life of the MVS, please be sure to read all safety instructions carefully.

2.1 General safety rules



Danger

There is a danger of electric shock if you touch the power grid or the contacts, terminals, etc. connected to it inside the equipment!

- Do not touch terminals or conductors connected to the power grid circuit.
- Pay attention to all instructions or safety instructions regarding connection to the power grid.



Danger

Lethally high voltage exists inside the product !

- Heed and follow warning signs on the product.
- Observe the safety precautions listed in this manual and other documentation related to this equipment.



Danger

Damaged equipment or system failure can cause electric shock or fire !

- Preliminary visual inspection of equipment for damage or other hazards before operation.
- Check whether other external equipment or circuit connections are safe.
- Make sure the equipment is in a safe state before operation.



Warning

The installation and operation of the MVS must comply with the relevant standards and regulations of the country where the project is located.



Warning

Make sure that the installation environment (such as voltage, temperature, humidity, altitude, pollution level, waterproof and dustproof level) is within the allowable range.



Warning

Before operation, the locking device on the pressure relief valve must be removed. For details, refer to 7-1 Removing the locking device of the pressure relief valve".



Warning

Mechanical installation, electrical connection, commissioning, maintenance and troubleshooting must be performed by professional technicians in accordance with local regulations. Before operation, the operator should read this manual completely and master the safety issues related to the operation.

2.2 Ground fault protection



Danger

When a ground fault occurs in a photovoltaic system, lethally high voltages may be present in the uncharged part. If accidentally touched, it is very dangerous! Before operation, please make sure that there is no ground fault in the system, and at the same time, take relevant protective measures.

2.3 Live measurement



Danger

Before making electrical connections, make sure that the MVS and its internal electrical equipment are in good condition. All electrical connections must comply with local country/ regional electrical standards.



Danger

There are high voltages in the equipment in the MVS, accidental touch may cause a fatal electric shock hazard, so during live measurement, you should:

- Take precautions (such as wearing insulating gloves, etc.).
- There must be accompanying personnel to ensure personal safety.

2. 4 Use of measuring equipment

In order to ensure that all electrical parameters meet the requirements during the electrical connection and commissioning of the MVS, relevant electrical measuring equipment shall be used.



Warning

- Choose high-quality measuring equipment whose range and usable conditions all meet the requirements of the site.
- Ensure that the connection and use of the measuring equipment are correct and standardized to avoid dangers such as arcing.
- In case of live measurement, protective work should be done (such as wearing insulating gloves, protective glasses, etc.)

2. 5 Complete power-off operation

Only when it is ensured that all equipment in the MVS, especially the MVS, is completely uncharged, all operations can be performed on it.

- During the entire operation, it is necessary to ensure that the escape route is unobstructed.
- Ensure that the power-off equipment will not be accidentally re-powered. After the MVS is completely out of operation, be sure to wait at least 5 minutes before operating the MVS to ensure that the MVS is completely uncharged.
- Use a multimeter and electrical testing equipment to ensure that the inside of the equipment is completely uncharged.
- Make necessary grounding and short-circuit connections after confirming that there is no electricity.
- Use insulating cloth to insulate and cover the operating parts near potentially live parts.

2. 6 Static electricity protection



Caution

Contact with printed circuit boards or other electrostatic sensitive components or improper operation may cause device damage. Please release static electricity before operation.

- Avoid unnecessary circuit board contact.
- comply with electrostatic protection specifications, such as wearing anti-static bracelets.

2.7 Body warning sign protection

The warning signs on the body of the MVS and the internal electrical equipment contain important information for the safe operation of the MVS and internal equipment. It is strictly forbidden to tear or damage it!

Caution

Do not tear or damage the sign.

- Ensure that the warning signs of the body are clear and readable at all times.
- Once the warning signs on the body are damaged or blurred, be sure to replace them immediately.

2.8 Safety warning sign setting

When carrying out on-site transportation, installation, overhaul, maintenance and other operations on the MVS, in order to prevent unrelated personnel from approaching and improper operation or accidents, please observe the following precautions:

- Place eye-catching warning signs at the front and rear of the MVS and at the switch to prevent accidents caused by wrong closing.
- Set up warning signs or safety tapes near the field operation area.

2.9 Daily operation and maintenance

During daily operation, it is necessary to ensure that the doors of the MVS and the internal equipment cabinets are closed and locked, and the keys have been pulled out and handed over to a special person for safekeeping. In order to avoid accidents caused by unauthorized personnel entering, or the internal equipment is exposed to rain, animals, etc. At the same time, the MVS and internal equipment should be regularly inspected and maintained to ensure long-term reliable operation of the MVS.



Warning

If the relevant operations are carried out when the equipment is live, be sure to do insulation protection, and ensure that at least two staff are on site at the same time.

The photovoltaic power station where the MVS is located is usually located in the field environment away from the urban area. Corresponding field rescue facilities shall be prepared as required for implementation when necessary.



Warning

The equipment should be operated in accordance with local laws and regulations and strictly follow the safety precautions specified in this manual.



Warning

Before servicing or replacing equipment, make sure that the MVS is powered off and the high-side and low-side switches are disconnected.

In daily operation and maintenance, please pay attention to the following:

- The nameplate is affixed to the MVS. It also contains important parameter information of the equipment. Protect the nameplate during all operations.
- Wear appropriate personal protective equipment, such as safety glasses, safety shoes and safety gloves, during all operations.
- It is recommended to take all necessary auxiliary measures to ensure personal and equipment safety.

2. 10 Other precautions

2. 10. 1 Manual storage

The product manual is an integral part of the product. The manual contains important information on transport, installation, inspection, maintenance, etc. of the MVS. Please read this manual carefully before transporting, installing, overhauling and maintaining the MVS.

- Please strictly follow the description in this manual to transport, install, overhaul and maintain the MVS. Otherwise, equipment damage, personal injury or property damage may be caused.
- This manual should be kept in a safe place so that it is readily available to transport, installation and operating personnel.

2. 10. 2 Product Scrap

When the MVS as a whole or the individual equipment inside needs to be discarded, it cannot be treated as general waste. Some components of the internal machine can be recycled and reused, and at the same time, some components will pollute the environment. Please contact the local authorized professional recycling organization to properly dispose of the product and internal components.

2. 10. 3 Manual Instructions



In order to facilitate users to read and use this manual better, a lot of pictures are arranged in the manual. The pictures are for illustrative purposes only. For the specific details of the product, please refer to the actual product received.



Please keep this manual and other related documents close to the equipment. In order to prepare for installation, operation, maintenance, repair and access at any time.



All descriptions in this manual are standard for MVSs. If users have special needs, please explain to GoodWe staff when ordering. We will try our best to meet your needs. For the specific details of the product, please refer to the actual product you receive.

This manual cannot cover all possible situations during installation, operation, maintenance, overhaul, etc. If you encounter situations that are not explained in the manual, please contact GoodWe in time.

3 Product Description

3.1 External design of the cabinet

3.1.1 View

GW7000K-MVS

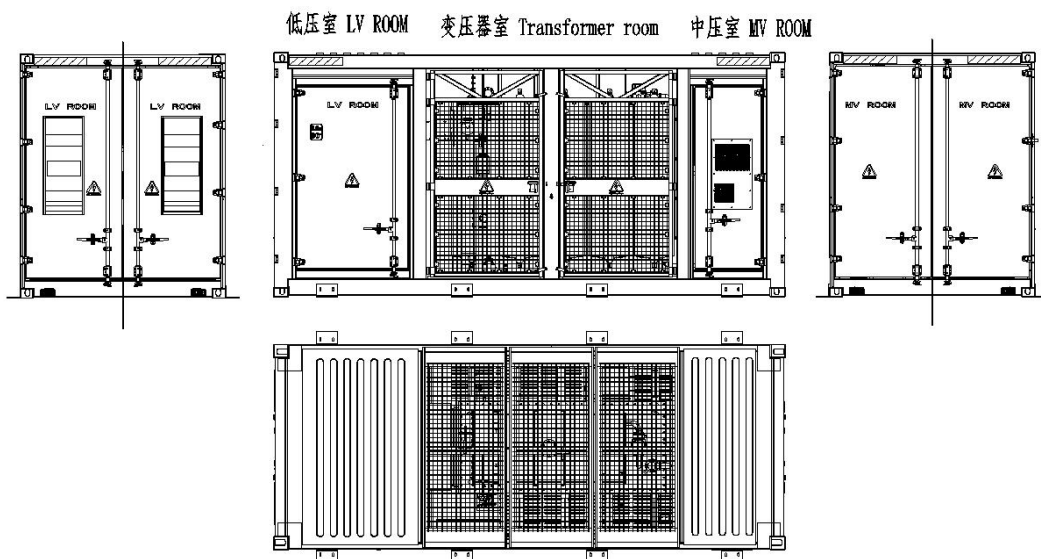

Unless otherwise stated, the rest take GW7000K-MVS as an example to briefly introduce the installation and wiring process of the MVS.

3. 1. 2 Equipment composition

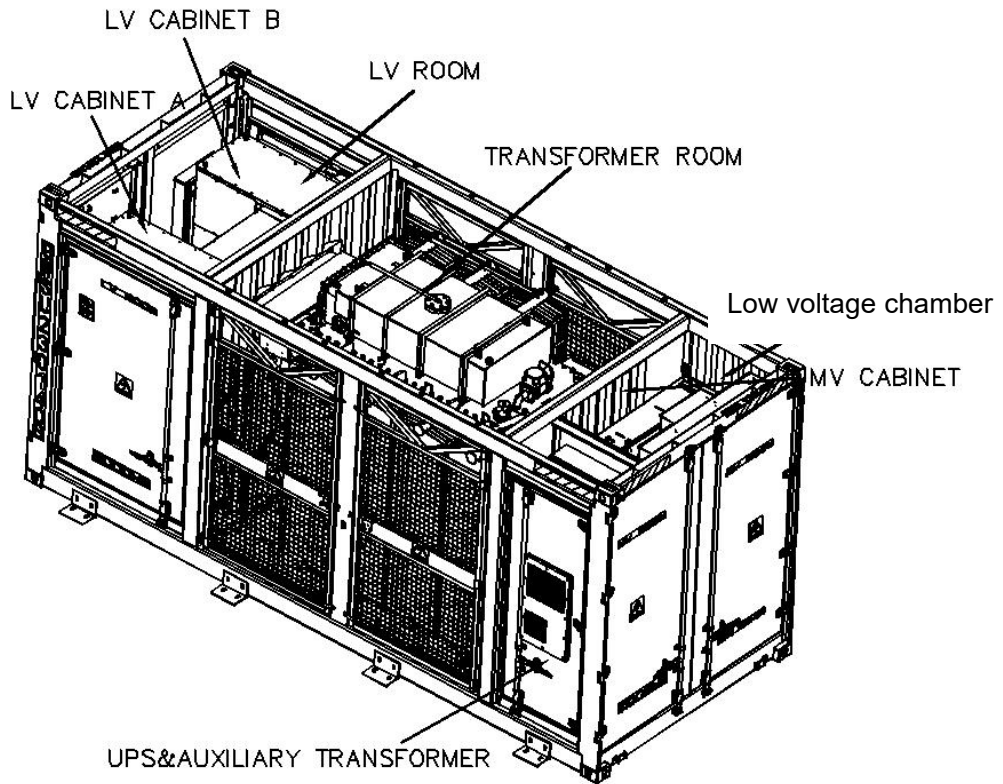

NO.	Name	Description
1	Low voltage chamber	Including low-voltage wiring areas, low-voltage inlet holes, etc., which can be connected to photovoltaic inverters
2	Transformer	Contains a medium voltage transformer. A medium voltage transformer can convert the low voltage output by the inverter to a grid compatible medium voltage.
3	Medium voltage chamber and Low voltage power distribution room	The power distribution room is located on the front, which contains a communication box and a low-voltage power distribution cabinet, auxiliary transformer, and UPS emergency power supply. The medium voltage chamber is located on the back and contains a medium voltage ring network cabinet inside.

3. 1. 3 Mechanical Dimensions

Wide (W)	Height (H)	Depth (D)
6,058 mm	2,896 mm	2,438 mm

3. 1. 4 Maximum door opening size

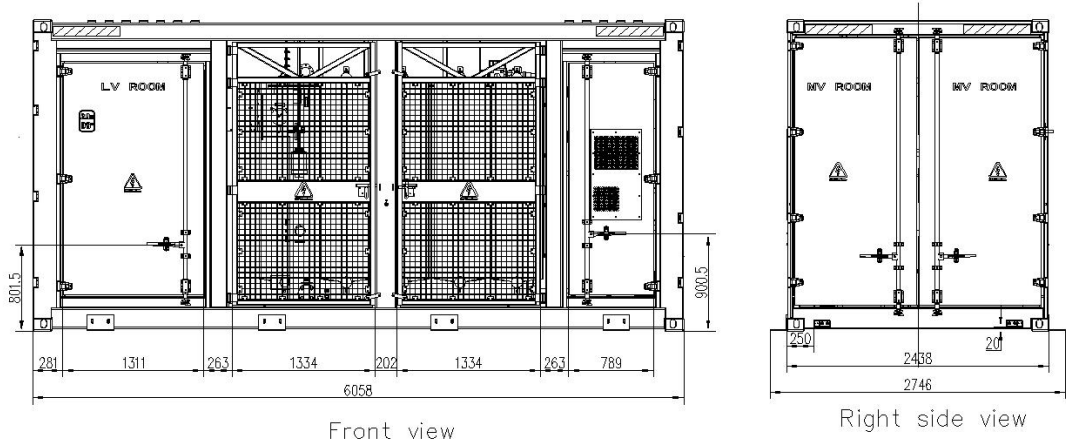

When the doors in all directions of the cabinet are opened, the maximum opening size is as shown in the figure below.

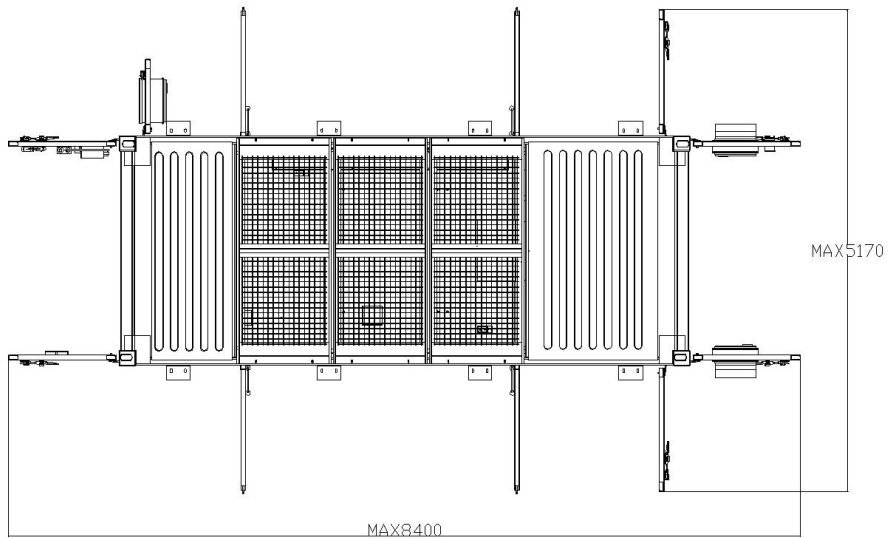

3.2 Internal design of the cabinet

3.2.1 Internal equipment composition

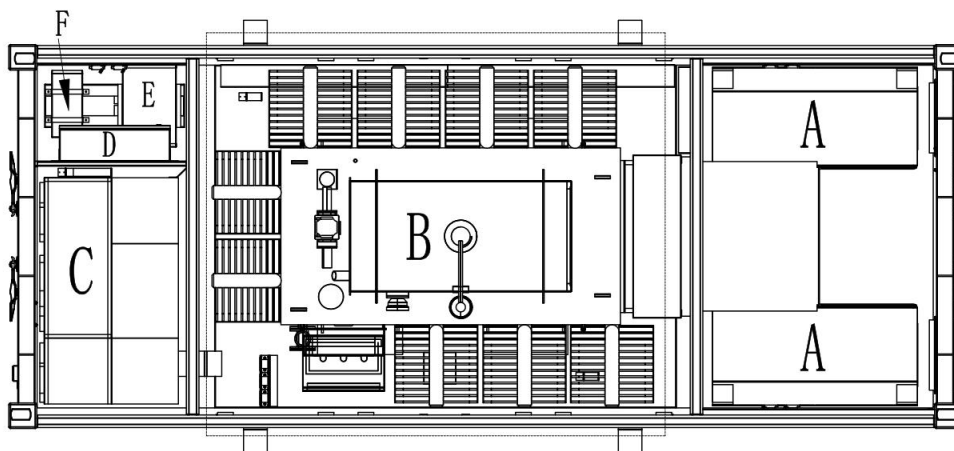

NO.	Name
A	Low voltage chamber
B	Transformer
C	Medium voltage ring network cabinet
D	communication box and power distribution cabinet
E	SG-10~20kVA dry-type transformer
F	UPS

3.2.2 Bottom cable entry hole

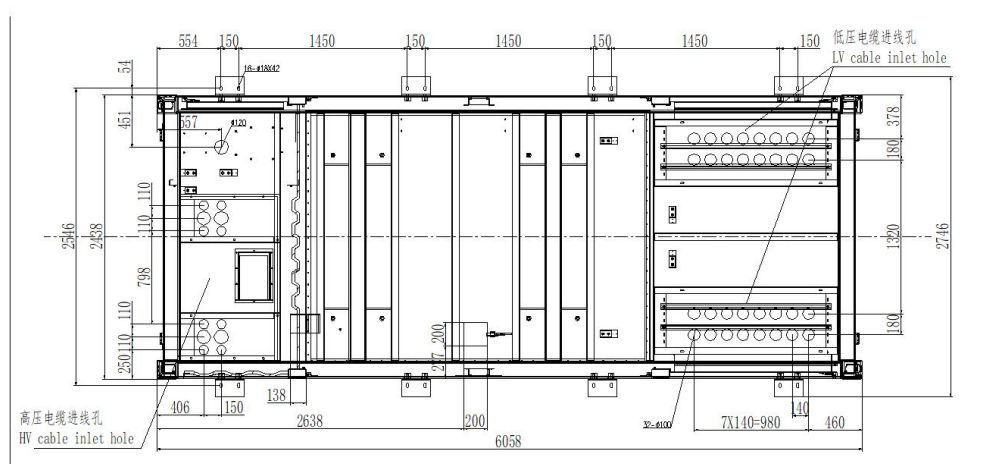

Taking GW7000K-MVS as an example, the bottom wire entry holes are as follows:

NO.	Name	Description
A	Low voltage inlet hole	All cables connected to the low-voltage cabinet enter through this hole.
B	Medium voltage inlet hole	All cables connected to the medium voltage grid are inserted through this hole.
C	Communication and power distribution inlets	All cables connecting with external communication equipment and power supply equipment enter through this hole.
D	Oil storage box	Facilitate the leakage of transformer oil to the oil storage box.

3.2.3 Medium voltage cable entry hole

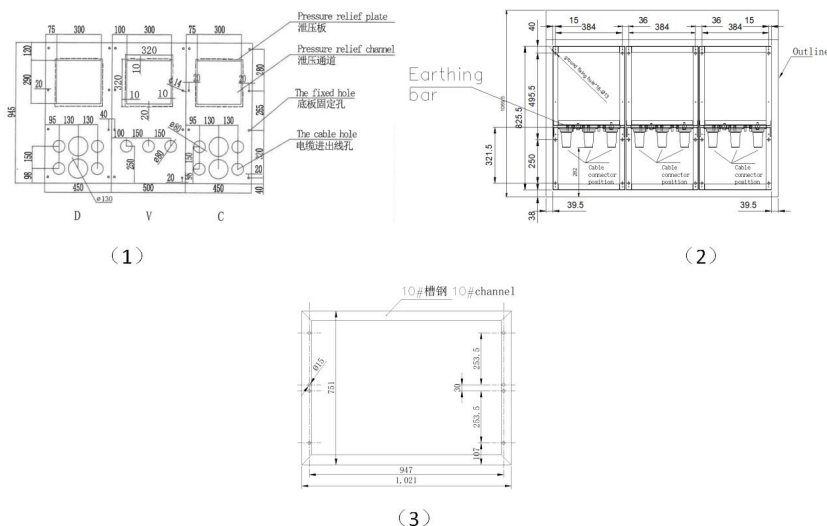

Table 3-1 Cable entry hole at the bottom of the ring network cabinet

Ring network cabinet brand	Grid voltage	Size
Daqo	33kV	Reference photo (1)
ABB	30kV	Reference photo (2)
ABB	10kV、20kV	Reference photo (3)

3.2.4 Internal Devices

The MVS consists of low voltage cabinet, transformer room, medium voltage cabinet and power distribution room.

3.2.5 Low voltage cabinet

The low-voltage cabinet is located in the low-voltage room of the MVS,

and is used to combine the cables input by the inverter, boost the voltage through the medium-voltage transformer, and finally feed it into the grid. The low-voltage cabinet consists of low-voltage cabinet A and low-voltage cabinet B, and the design of the two cabinets is the same. Taking GW7000K-MVS as an example, the following figure shows the internal components of the cabinet.

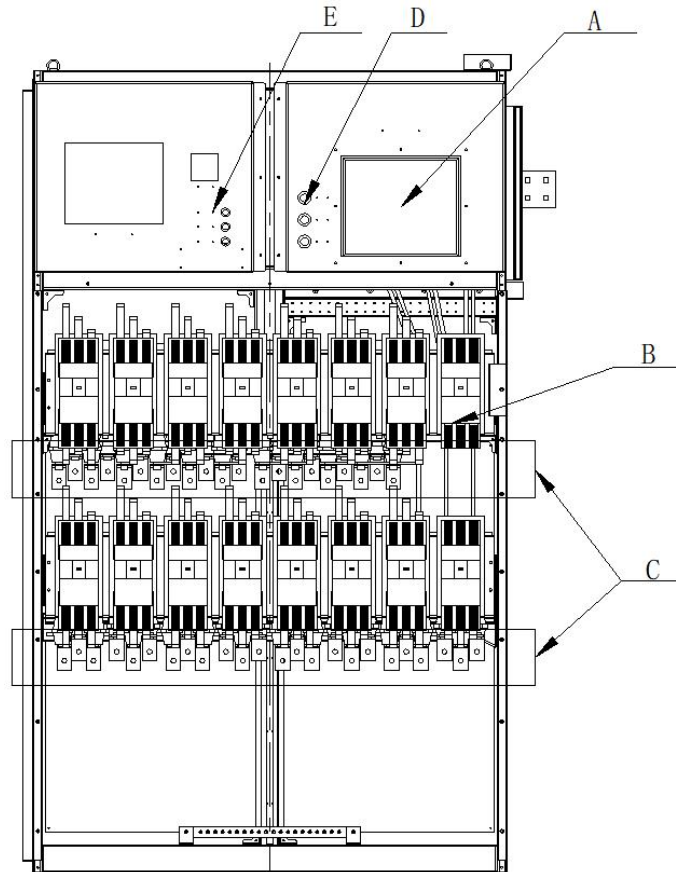





***is optional. The picture is for reference only, the actual product shall prevail.**

Area	Name	Effect
A	Frame circuit breaker	Inside low-voltage cabinet A, it is used to connect/disconnect cabinet A. Inside low-voltage cabinet B, it is used to connect/disconnect cabinet B.
B	Molded case circuit breaker	Used to connect/disconnect the corresponding terminal.
C	Low voltage wiring area	Connect to the front inverter.
D*	Control knob	Control mode for setting the circuit breaker: remote, local. Turn the control knob to the "Remote" position to set it to remote control. Turn the control knob to the "local" position to set it to local control.
E	Lock box	Three lock heads are interlocked to lock the operating key.



3.2.6 Transformer room

The transformer room mainly contains a medium voltage transformer. The transformer integrates accessories such as pressure relief valve, step switch, oil level gauge, pressure gauge, oil temperature gauge, oil filling valve and oil drain valve. The functions of each accessory are shown below.

Photo	Name	Description
	Oil filling valve	When the oil level in the transformer tank is low, open the oil filling valve.
	Pressure relief valve	When the oil pressure in the tank reaches 55kPa, the valve will automatically release.
	Pressure gauge	The pressure gauge is used to read the pressure value inside the oil tank.
	Oil level gauge	<p>If the oil level value falls below the lowest mark on the oil level gauge or below the oil level mark required for safe operation of the transformer, the transformer will stop running.</p> <p>When the oil level is too high, open the oil drain valve to lower the oil level.</p> <p>When the oil level is too low, disconnect the transformer and check the oil tank for oil leakage.</p>
	Oil temperature gauge	<p>The oil temperature alarm temperature is 90°C. When the oil temperature reaches this value, the alarm signal will be sent to the intelligent power distribution cabinet or client communication device.</p> <p>The oil temperature trip temperature is 100°C. When the oil temperature reaches this value, the trip signal will be sent to the intelligent distribution cabinet or client communication device. At the same time, the transformer will be disconnected from the front and rear stage equipment.</p>



The picture is for reference only, the actual product shall prevail. a), b) The parameters noted are factory default values, which can be adjusted according to the actual situation.

Photo	Name	Description
	Winding Thermometer	The oil temperature alarm temperature is 90°C. When the oil temperature reaches this value, the alarm signal will be sent to the intelligent power distribution cabinet or client communication device. The oil temperature trip temperature is 100°C. When the oil temperature reaches this value, the trip signal will be sent to the intelligent distribution cabinet or client communication device. At the same time, the transformer will be disconnected from the front and rear stage equipment.
	Oil drain valve	When the oil level is too high or maintenance is required, the oil drain valve needs to be opened.
	Step switch	The step switch has five positions: 1, 2, 3, 4, and 5. For more details, refer to "Figure 7-2 Voltage Ratio Adjustment by Step Switching".



The picture is for reference only, the actual product shall prevail.

a), b) The parameters noted are factory default values, which can be adjusted according to the actual situation.

3. 2. 7 Medium voltage cabinet

The medium voltage cabinet contains a medium voltage ring network cabinet.

The ring network cabinet consists of a circuit breaker cabinet, a load switch cabinet and a directly connected cable cabinet. Cabinet names vary with cabinet manufacturers, as shown in the following table.

Manufacturer	Siemens	ABB	Ormazabal
Load switch cabinet	R	C	C
Circuit breaker cabinet	L	V	V
Directly connected cable cabinet	K	D	D

Taking the 36kV DVC combination cabinet of Daqo brand as an example, the appearance of the ring network cabinet is as follows:

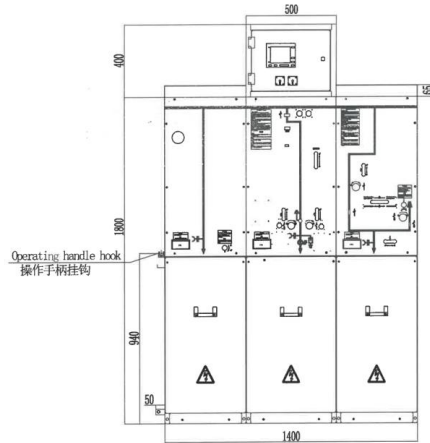

3.2.8 Power distribution room

The power distribution room is composed of communication box, distribution box, auxiliary transformer and UPS.

The appearance and internal layout of the communication box are shown below.

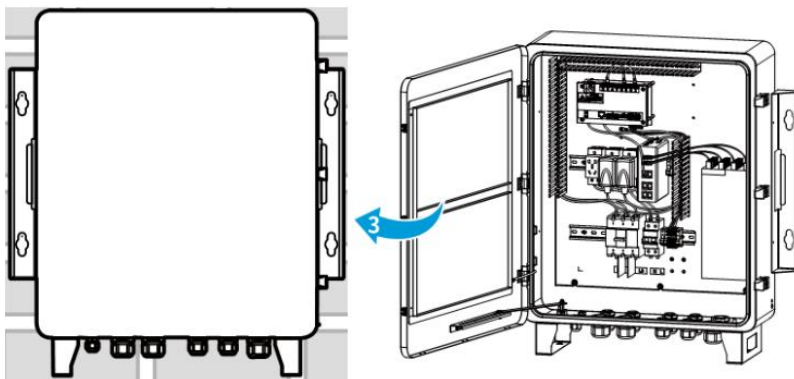

Power distribution room

The internal layout of the power distribution room is shown below.

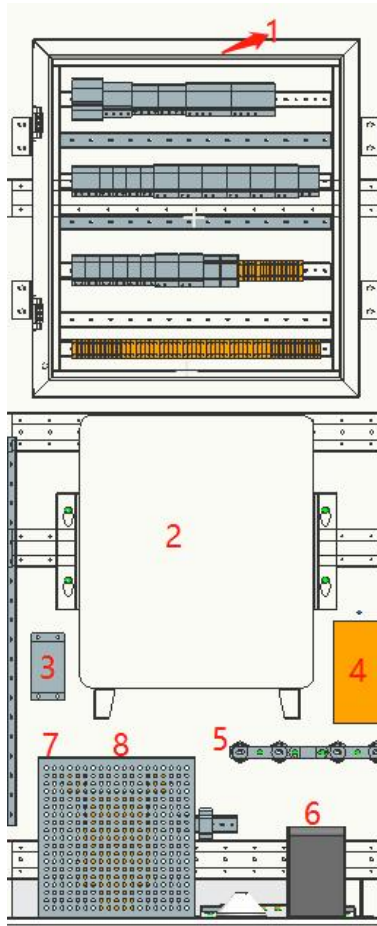

1. Power distribution cabinet
2. Communication cabinet
3. Heating panel
4. Fiber optic box
5. Connecting copper bar
6. UPS
7. Transformer cover
8. Dry-type transformer

The picture is for reference only, the actual product shall prevail.



Our company does not provide the communication box, the model is specified by the customer. The details are determined by the order agreement.

4 Identify and store MVSs

4.1 Identifying MVSs

The MVS can be identified by the nameplate. The information contained in the nameplate includes: model, main technical parameters, certification body identification and origin, etc.



Warning

The nameplate contains important parameter information, which should be protected during transportation, installation, maintenance, overhaul and other operations. Destruction or dismantling is strictly prohibited!

4.2 Check the integrity of transportation

Before leaving the factory, the staff of GoodWe has conducted a comprehensive and careful inspection of the MVS, and packaged it firmly. Nonetheless, it is possible that the device may be bumped or even damaged during transportation.

After receiving the box, it is first necessary to check the integrity and integrity of the transportation. At least the following items shall be carefully checked: check whether all shipped components are complete according to the packing list.

- Confirm that the received machine is consistent with the ordered model.
- Carefully check the MVS and internal equipment to see if there is any damage during transportation.



Warning

Only complete and undamaged MVSs can be installed and commissioned!

Before starting the installation make sure that:

- **The MVS itself is intact and without any damage.**
- **All equipment in the MVS is in good condition without any damage.**

4.3 Storage

After the successful completion of the delivery work, if it is not installed immediately, please store the MVS properly as described in this section.

- In order to prevent condensation in the MVS or the bottom of the box from being soaked by rainwater in rainy season, the MVS shall be stored in an indoor environment, such as a large warehouse or workshop.
- If it must be stored outdoors due to site conditions, the MVS base must be raised. The specific lifting height shall be reasonably determined according to site geological and meteorological conditions.
- Storage environment temperature: $-35^{\circ}\text{C} \sim +70^{\circ}\text{C}$; Relative humidity of storage environment: $0 \sim 95\%$, no condensation. When the ambient temperature is too low, provide heating for the internal equipment of the MVS. The MVS shall be stored on a dry, flat, solid ground with sufficient bearing capacity and no vegetation cover. The storage ground must be flat and free of water, unevenness or undulation.
- When storing, ensure that the doors of the MVS and the internal equipment cabinets are locked, and the cabinet doors of the MVS and equipment inside the cabinet are locked tightly.
- Effective measures must be taken to prevent rain, sand and dust from entering the MVS. At least the air inlet and outlet of the MVS must be effectively protected.
- During storage, lock the MVS and internal equipment door locks. Take appropriate protective measures (at least the air inlet and outlet should be sealed) to prevent rain and dust from entering the MVS.
- When selecting the temporary storage platform, the supporting feet of the MVS shall be taken into account. Check the MVS and internal equipment regularly (at least every half month).

5 Mechanical installation



Warning

During the whole process of mechanical installation, the relevant standards and requirements of the project location must be strictly followed.

5.1 Conditions of transportation

All kinds of equipment in the MVS have been installed and fixed in the MVS before leaving the factory, and the MVS can be hoisted and transported as a whole during transportation.

The MVS is transported to the site of the power station by the freight company, and the site management personnel of the power station will be notified in advance to negotiate and arrange delivery and unloading. After delivery, the MVS is moved to the final position, which needs to be operated by the engineering construction personnel of the power station.



Warning

During the whole process of loading, unloading and transportation, the operation safety regulations of the country/region where the project is located must be observed!

- Any machines and tools used in the MVS and operation shall be maintained.
- all personnel engaged in loading, unloading and bolting shall receive corresponding training. especially safety training.



During the whole process of loading, unloading and transportation, it is necessary to keep in mind the dimensions and weight parameters of the MVS.

Transport and mobile MVSs should at least meet the following conditions:

- Each cabinet door of the MVS is locked tightly.
- According to the site conditions, select the appropriate means of transport, usually a crane or a forklift. The selected means of transport must have sufficient load-bearing capacity.
- Additional traction devices may be required if required to move on slopes etc.
- Remove all obstacles that exist or may exist during the movement, such as trees, cables, etc.
- The MVS should be transported and moved under favorable weather conditions as far as possible.
- Before transportation, be sure to use a flexible rope to fix the lifting ring on the

top of the MVS to the platform base, and then fix the four fixing points on the bottom of the platform to the fixing points of the transport vehicle.

In addition, when the MVS is grounded, it should also be ensured that:

- The ground of the MVS should be solid and flat, well drained, free from obstacles and protrusions;
- On site, the MVS shall be supported by only four bottom corner pieces.

5.2 Lifting and transporting

5.2.1 Precautions for lifting



Warning

- **During the whole process of hoisting the MVS, it is necessary to strictly follow the safety operation rules of the crane.**
- **It is strictly forbidden to stand within the range of 5m to 10m in the operating area. In particular, it is strictly forbidden to stand under the hoisting arm and under the hoisted or moving machine to avoid casualties.**
- **In case of bad weather conditions, such as heavy rain, heavy fog, strong wind, etc., the lifting work should be stopped.**

When lifting a MVS, at least the following requirements must be met:

- Safety on site must be ensured when lifting.
- When carrying out lifting and installation operations, there should be a professional on-site commanding the whole process.
- The strength of the slings used should take into account the weight of the MVS.
- The crane shall have sufficient arm length and rotation radius.
- Ensure that all sling connections are safe and secure.
- The length of the sling can be adjusted appropriately according to the actual requirements of the site.
- Smoothly transport the MVS.
- Transport the MVS by connecting the four top corner fittings.
- Take all necessary auxiliary measures to ensure the safe and smooth lifting of the MVS.
- All cabinet doors should be closed and locked.
- It is recommended to lift from left to right or right to left to ensure smooth lifting.

The figure below shows the schematic diagram of crane operation in the lifting process of the MVS.

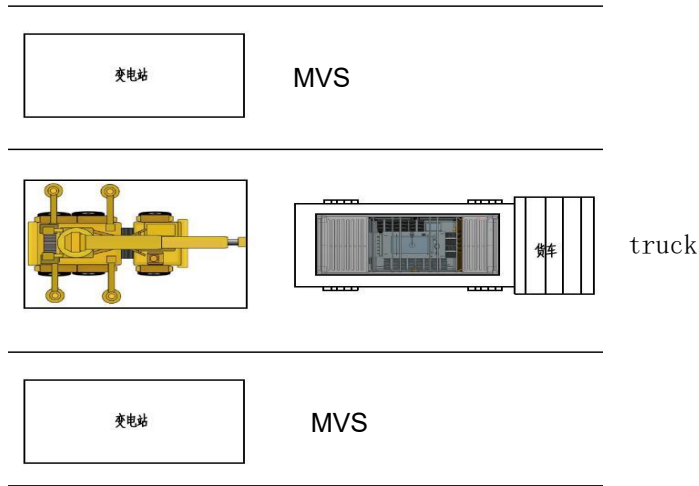

5-1 Schematic diagram of lifting

5. 2. 2 Lifting

In the process of hoisting the MVS, each operation link should be carried out according to the following requirements:

- The MVS shall be lifted vertically without dragging on the ground or on the top of the lower box, and the MVS shall not be dragged or pushed on any surface.
- Keep it stable, and the diagonal of the cabinet should be inclined $\leq 5^\circ$.
- After the MVS is moved 50mm away from the support surface, it shall be suspended, and the connection between the lifting equipment and the MVS shall be checked. The lifting can be carried out only after the connection is confirmed to be firm.
- The lifting equipment shall be lifted and put down gently. The cabinet shall fall slowly and steadily to avoid impact on the internal equipment.
- When the cabinet is in contact with the base, remove the hoisting steel cable after the base is evenly stressed.
- The installation location should be firm, horizontal and well drained. The MVS is supported by four bottom fittings on the ground.
- After placing the MVS on the base at a constant speed, remove the fixing rope in time.
- After the first hoisted container is fixed, the subsequent container hoisting can be carried out.

The MVS should be lifted by four top corner pieces, as shown in the figure below

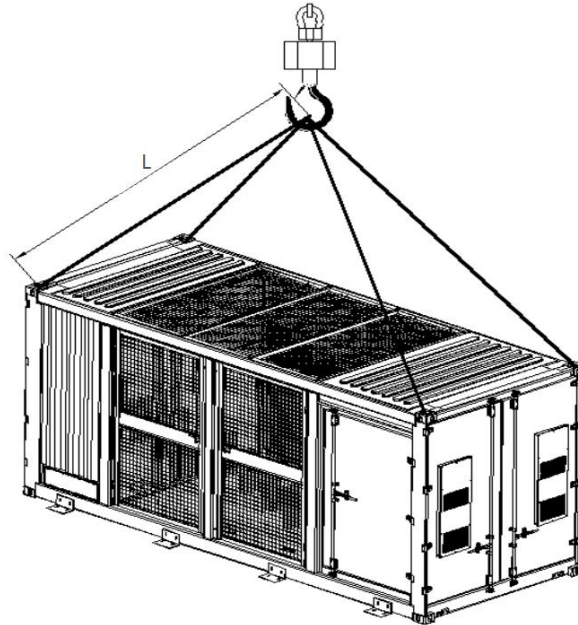

Figure 5-2 Top lifting method

Project	requirements
Steel cable length	>6.5m
Number of steel cables	4 sticks

5.2.3 Fastening of connectors

The suspended ceiling of the MVS can be carried out by using slings with hooks or U-hooks. The lifting device shall be properly connected with the MVS cabinet.

Lifting device	cliver	U-shaped hook
连接示意 Connection diagram		
Attention	Hooking should be done from the inside out, not from the outside in	The horizontal pin must be tightened



Warning

- **When lifting and transporting, all safety operation standards and regulations of the country/region where the project is located must be strictly observed.**
- **GoodWe shall not be liable for any personal injury or property loss caused by violation of relevant requirements or other safety specifications.**

5.3 Building the foundation

5.3.1 Selection of installation site

When choosing an installation site, please follow at least the following principles:

- The climate environment and geological conditions (such as stress wave emission, groundwater level) and other characteristics of the MVS installation site should be fully considered.
- The surrounding environment is dry and well ventilated, away from flammable and explosive areas.
- The soil at the installation site needs to have a certain degree of compaction. If the soil is loose, please take measures to ensure the foundation is stable.
- It should be kept away from places that generate dust, oily smoke, harmful gases, and produce or store corrosive, flammable, and explosive materials.
- The installation location cannot be in a low-lying area and the site level should be higher than the historically high water level in the area.
- The soil is in good condition, the ground is firm, and there must be no bad geological conditions such as rubber soil and weak soil layers. Do not choose the ground that is easy to accumulate water and sink.
- A well-ventilated place.
- Choose an open location to ensure that there are no obstacles within 10m from the equipment.
- Keep a distance of at least 50m from residential areas to avoid noise pollution.

5.3.2 Recommended foundation scheme

At least the following requirements shall be met when constructing the foundation:

Warning

The specific foundation scheme is determined by the on-site investigation of the local construction team. The following is for reference only, and should not be taken as the standard. All hoisting and foundation construction during the installation of the box transformer must be designed and operated by holding relevant certificates or professionals.

- The bottom of the foundation pit where the foundation is built must be compacted and filled.
- The foundation should be sufficient to provide effective load-bearing support for the MVS.
- Elevate the MVS to prevent rainwater from eroding the MVS base and interior. It is recommended that the foundation be about 100mm higher than the horizontal ground of the installation site.
- Build cement foundations of sufficient cross-sectional area and height. The foundation height is determined by the construction party according to the site geology.
- Cable routing should be considered when constructing foundations.

The overall foundation construction effect is shown in the figure below.

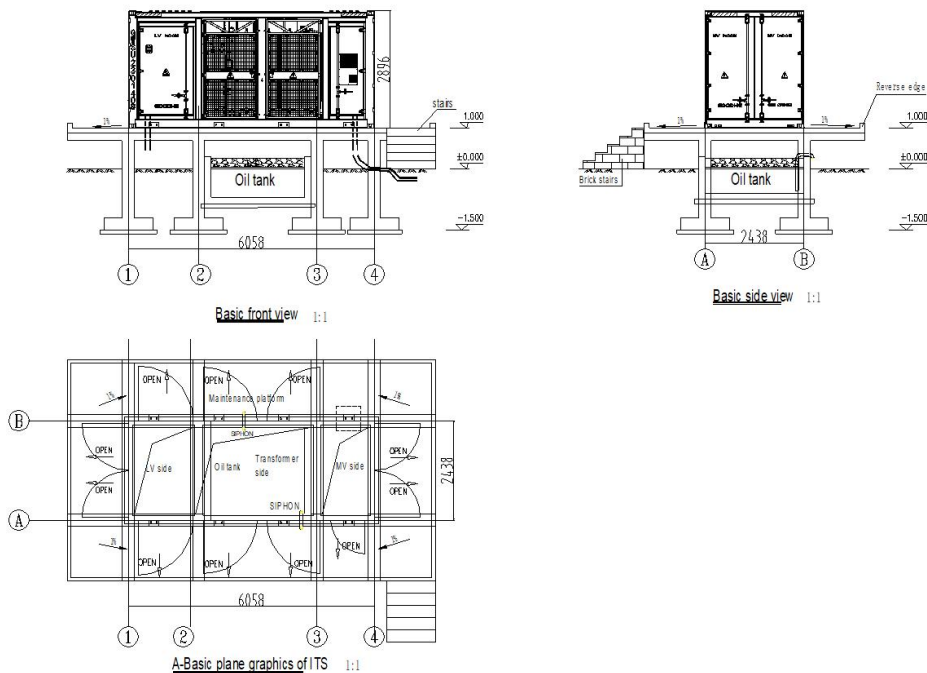

5. 3. 3 Fixed MVS (optional)

Introduction

As shown in Figure A below, there are L-shaped angle steel mounting holes reserved at the bottom of the MVS.

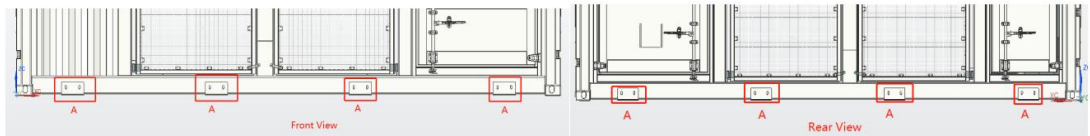

Preparation of installation tools

When installing L-shaped angle steel, the tools that may be used are as follows:

No.	Name	Component source
1	L-shaped steel	Included in the scope of supply
2	M16*50 expansion bolt	Not included in the scope of supply
3	M16*35 screws	Included in the scope of supply

L-shaped steel appearance drawing

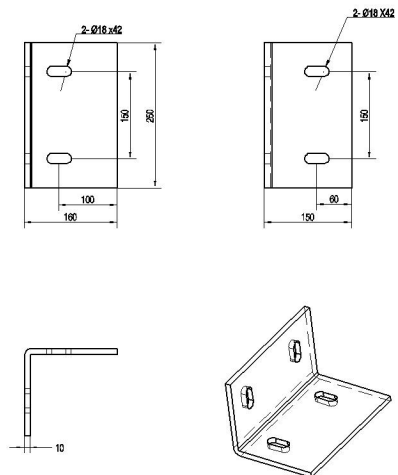
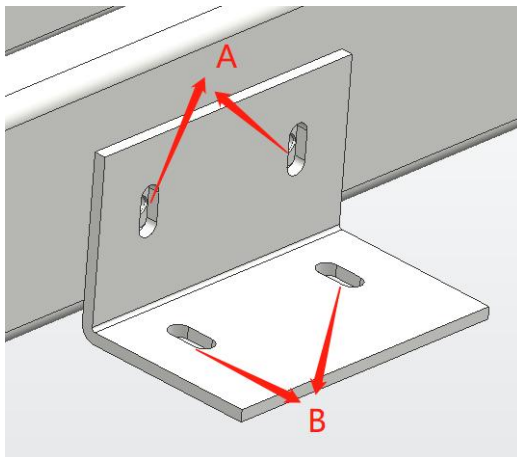

First, tighten M16*35 screws at A, and then M16*50 expansion bolts at B, pass through from bottom to top, and add spring washers, flat washers and nuts to fix them above the angle steel.

Other protective measures

Notice

Drainage systems should be designed at the installation site to prevent the MVS from being immersed in water during heavy rains.

Notice

Do not plant any trees near the MVS installation site to avoid MVS damage due to leaves or stems.

5.4 Installation check

- Bolts and nuts are tightened.
- The cabinet body is in good contact with the base below and bears even force.
- All doors open and close smoothly.

5.5 Installation space requirements

In the field, the MVS needs to be used together with the inverter, and the distance between the inverter and the MVS is as follows.

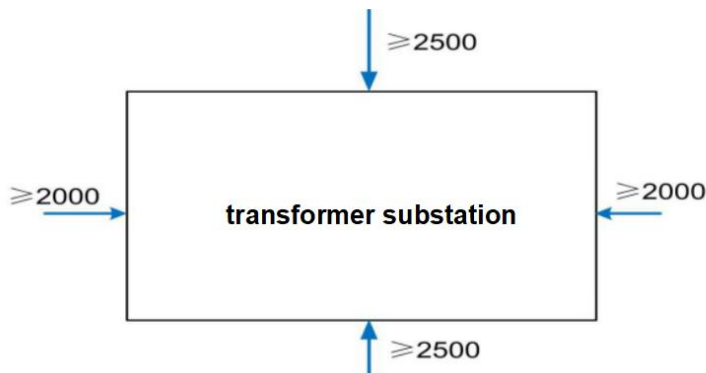

*The distances shown above are minimum requirements.

5.6 Remove the film and box converter cover

In the process of transportation, the heat exchanger and air conditioning in the MVS are equipped with film and PVC clip mesh cloth protective covers for packaging, as shown in Figure A and B below respectively.

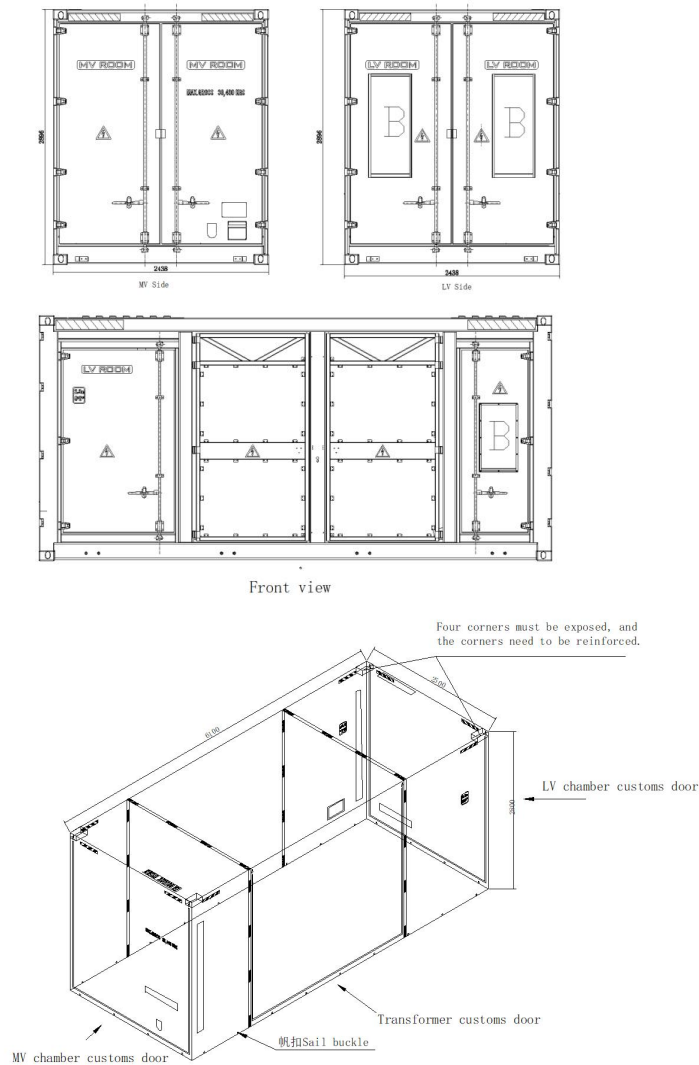

Before the MVS is officially put into operation, be sure to remove the above film and box PVC clip mesh cloth protective cover.

6 Electrical connections

6.1 Safety Instructions

6.1.1 General



Danger

High voltage danger! Danger of electric shock!

- Do not touch live parts!
- Before installation, make sure that the MVS and its internal equipment are not live.
- Do not place the MVS on flammable surfaces.



Danger

When a ground fault occurs in a photovoltaic system, lethally high voltages may be present in the parts that are not energized. Very dangerous if accidentally touched! Before operation, please ensure that there is no ground fault in the system, and at the same time, take relevant protective measures.



Warning

All electrical connections must comply with the relevant standards and codes of the country where the project is located.

The MVS can only be connected to the grid side after it has been approved by the local power supply company and installed by professional technicians.



Warning

Only professional electricians or qualified personnel can electrically connect this product.



Warning

Before wiring, turn off all switches.



Warning

The entry of wind, sand and moisture may damage the electrical equipment in the MVS or affect the operation performance of the equipment!

- **In windy and sandy seasons, or when the relative humidity in the surrounding environment is greater than 95%, electrical connection shall be avoided.**
- **when there is no wind and sand, and the weather is clear and dry, start the connection work.**



Warning

Failure to comply with the torque requirements may cause fire at the connection! During the electrical connection process, the bolts must be tightened strictly to the torques described in this manual.



Warning

Too small bending radius or excessive winding may damage the optical fiber! When choosing optical fiber as the communication cable, please follow the relevant instructions of the optical fiber manufacturer on the minimum allowable bending



Warning

Only qualified electrical engineers can carry out work related to electrical connection. Please follow the requirements given in 2 Safety Instructions in this manual. GoodWe shall not be liable for any personal injury or property damage caused by ignoring these safety instructions.



Warning

When laying cables, ensure electrical insulation and comply with EMC specifications. Power cables and power and communication cables should be laid in layers. And when necessary, provide protection and support for the cable to reduce the stress on the cable.



Warning

Please strictly follow the wiring identification inside the device to perform wiring operations.

Notice

The installation design of the MVS must comply with the relevant standards or codes of the country/region where the project is located.

If the installation design requirements given in this manual are not followed, or the installation is not carried out in accordance with the relevant electrical standards or specifications of the installation location, resulting in MVS or system failure, it will not be included in the warranty scope.



To effectively reduce signal interference, it is recommended to use optical fibers for external communication cables.

6.1.2 The five security principles

During the whole process of electrical connection and all other operations on MVS and other equipment, the following five safety principles shall be observed:

- Disconnect all external connections of the MVS by professionals, as well as the connection with the UPS of the internal power supply of the equipment.
- Ensure that each disconnection is not accidentally re-energized.
- Use professional electrical inspection equipment to ensure that the inside of the equipment is completely de-energized.
- Have the necessary ground and short-circuit connections made by professionals.
- For possible live parts near the operating part, use insulating cloth to cover them.

6.1.3 Check and test the connecting cables before installing the transformer

Open the transformer door and check whether the high-low voltage cabinet and transformer are in good condition and whether the spare parts are in good condition. If any damage occurs, please inform the product supplier and conduct the transformer voltage test according to the test manual before installing the connecting cables.

6.2 Wiring schematic diagram

Taking GW7000K-MVS as an example, the primary electrical schematic diagram is as follows: (specifically, the drawings shall prevail).

Table 6-1 Device List

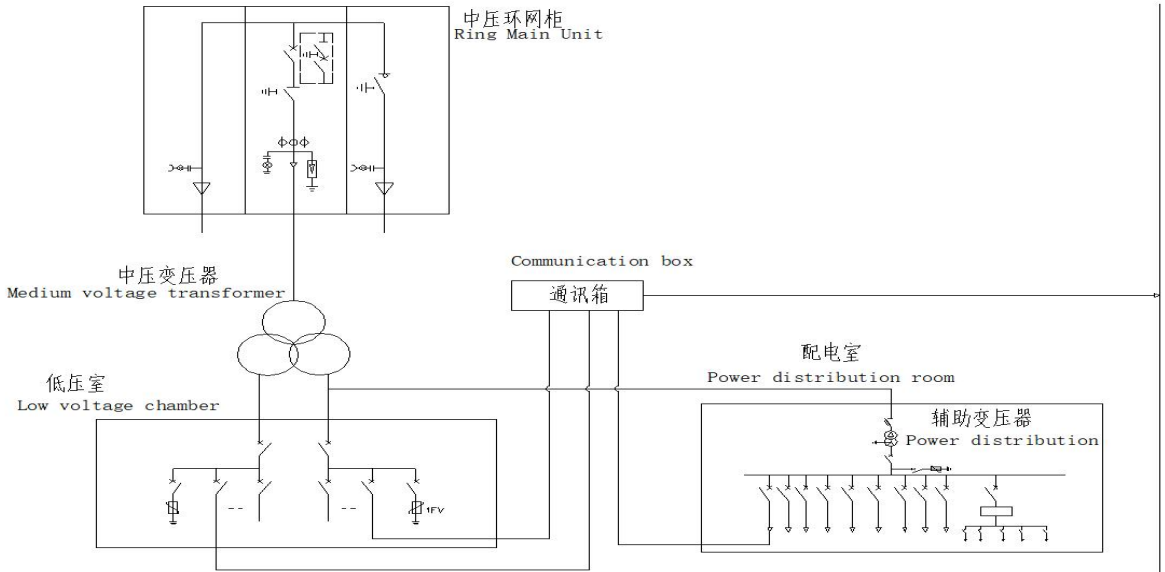

Area	Effect	Recommended Cable Specifications
Low voltage chamber	Low voltage busbar and inverter connection	Max. 400 mm ² aluminum wire
Ring network cabinet	Connect to the grid side	It is related to the brand and model of the ring network cabinet. For details, please refer to the manual of the ring network cabinet
Communication box	Communication port	485 line or optical fiber, etc.
Power distribution room	MVS Self-Powered Window	Copper flexible wire

6.3 Electrical connection

Before leaving the factory, the electrical connections between the equipments inside the MVS have been completed. On site, wiring between external equipment and MVSs is required, including grounding, low-voltage side wiring, medium-voltage side wiring, communication and power distribution wiring.

6.3.1 Grounding

Introduction

Grounding includes equipotential connection inside the MVS and grounding of external grounding points.

Equipotential connection inside the MVS

Before leaving the factory, the equipotential connection between all the equipment in the MVS has been completed, and they are uniformly summarized to the grounding copper bar.

External ground

In order to facilitate grounding, there are two grounding points outside the MVS cabinet.

Ground point dimensions, as shown below.

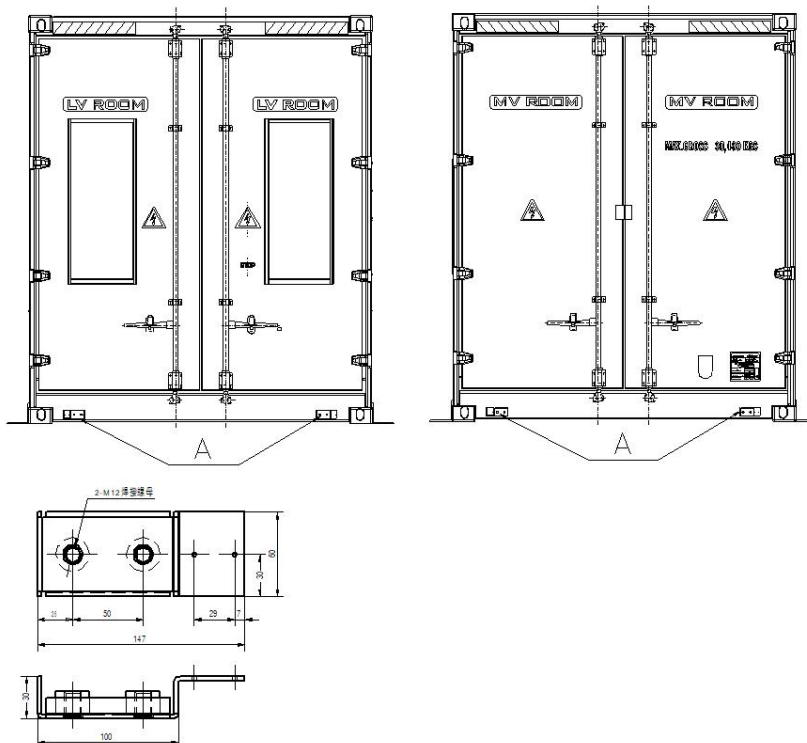

Measure the conductivity between the equipment grounding terminal and the total equipotential bonding copper bar to ensure the effectiveness of the internal grounding connection. The external grounding point of the MVS shall be reliably grounded through the following two methods.

- Use 50mm²~ 95mm² grounding cables to reliably connect the external grounding point of the MVS to the grounding point of the photovoltaic system. After completion, use M12 bolts to tighten.
- Weld the grounding flat bar to the external grounding point of the MVS. Finally, securely connect the ground flat bar to the photovoltaic system ground point. After completion, it is necessary to do anti-corrosion treatment on the weld part.

It is recommended to reliably connect two grounding points outside the MVS to the grounding point of the photovoltaic system.



The MVS needs to be grounded reliably. After completion, the following operations are required:

Measure the conductivity between the equipment grounding terminal and the total equipotential bonding copper bar to ensure the effectiveness of the internal grounding connection. Please perform external grounding according to the site conditions and the instructions of the actual staff.

After the ground connection is completed, the ground resistance must be measured, and the resistance value should not be greater than 4Ω.



The specific insulation resistance value should follow local standards and regulations.



Warning

During the ground connection process, if you have any questions, please contact the relevant staff in time. If the installation is not carried out in accordance with the installation specifications, or if it is installed or modified without permission, it may cause safety accidents or equipment damage. GoodWe Electric does not assume any responsibility for any loss caused thereby.

6.3.2 Low-voltage wiring

Taking GW7000K-MVS as an example, the low-voltage terminals are located in the lower part of the low-voltage cabinet, as shown in the

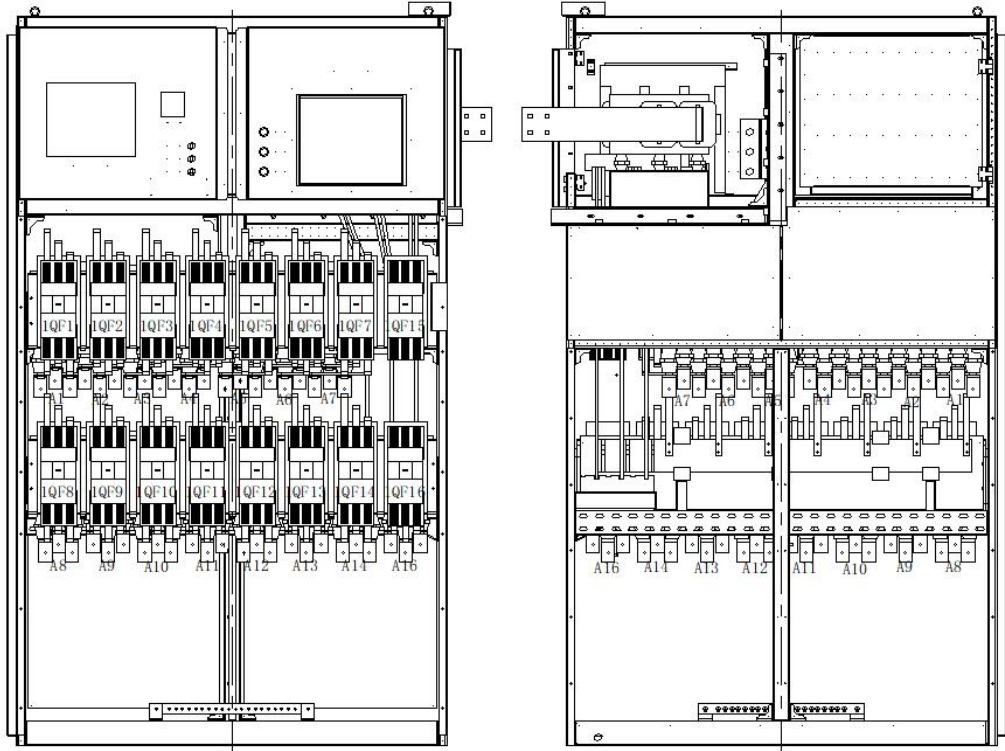

figure below.

Identifying wiring terminals

GW7000K-MVS includes 1QF16, 2QF16, 1QF1~1QF15, 2QF1~2QF15 and corresponding wiring terminals.

Taking GW7000K-MVS as an example, the corresponding relationship between low-voltage wiring terminals and low-voltage circuit breakers is as follows:

Correspondence table between low-voltage wiring terminals and low-voltage circuit breakers

Circuit breaker	Connecting terminal	Phase sequence
1QF1	A1	
1QF2	A2	
1QF3	A3	
1QF4	A4	
1QF5	A5	
1QF6	A6	
1QF7	A7	
1QF8	A8	L1, L2, L3 (From left to right)
1QF9	A9	
1QF10	A10	
1QF11	A11	
1QF12	A12	
1QF13	A13	
1QF14	A14	
1QF15	—	—
1QF16	—	—
2QF1	B1	
2QF2	B2	
2QF3	B3	
2QF4	B4	
2QF5	B5	
2QF6	B6	
2QF7	B7	
2QF8	B8	L1, L2, L3 (From left to right)
2QF9	B9	
2QF10	B10	
2QF11	B11	
2QF12	B12	
2QF13	B13	
2QF14	B14	
2QF15	—	—
2QF16	—	—

Wiring copper bar size

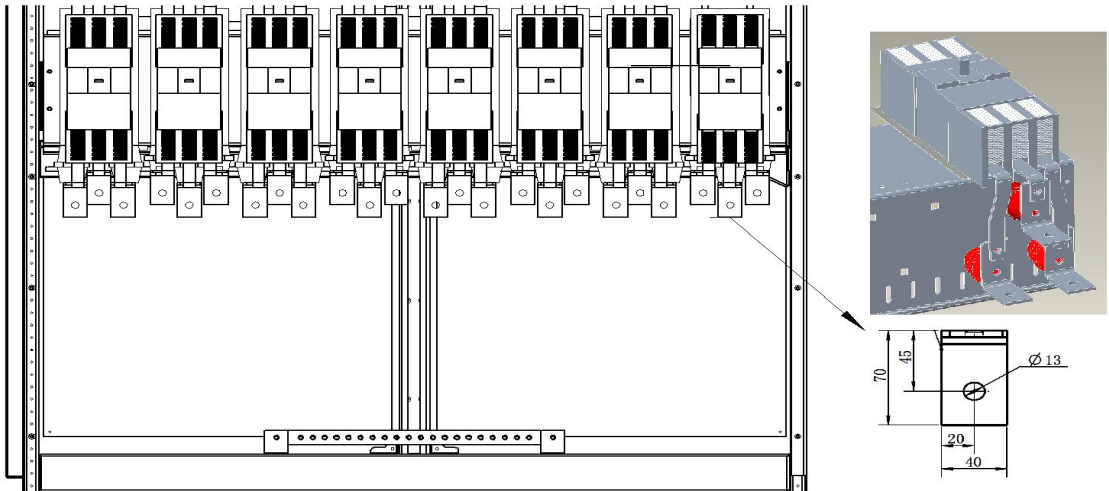

Step 1 Make sure that the output circuit breakers of each inverter at the previous stage are in the OFF state.

Step 2 Make sure that both the air circuit breaker and the molded case circuit breaker are disconnected.

Step 3 Thread the cable through the bottom inlet hole.

Step 4 Peel off the insulating skin at the end of the cable. The length of

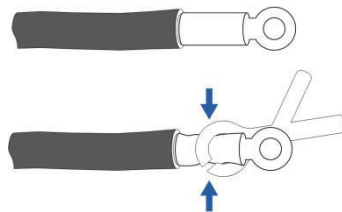

the peeling off of the insulating skin at the end of the cable shall be the depth of the wiring copper nose crimping hole plus about 5mm.

Step 5 Crimp the wiring copper nose. Equipped with appropriate wiring copper nose according to the selected cable size.

- 1 Place the exposed aluminum core of the stripped wire head into the wire pressing hole of the copper nose.
- 2 Use a terminal crimping machine to crimp the wiring copper nose. The number of crimps should be more than two.

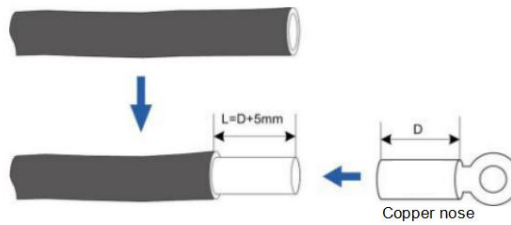

Step 6 Install the heat shrink tubing.

- 1 Choose a heat-shrinkable tube that matches the size of the cable, and the length should be about 2cm longer than the wiring copper-nosed crimping pipe.
- 2 Put the heat-shrinkable tube on the wiring copper nose to completely cover the crimping hole of the wiring copper nose.
- 3 Use a hot hair dryer to shrink the heat shrink tube.

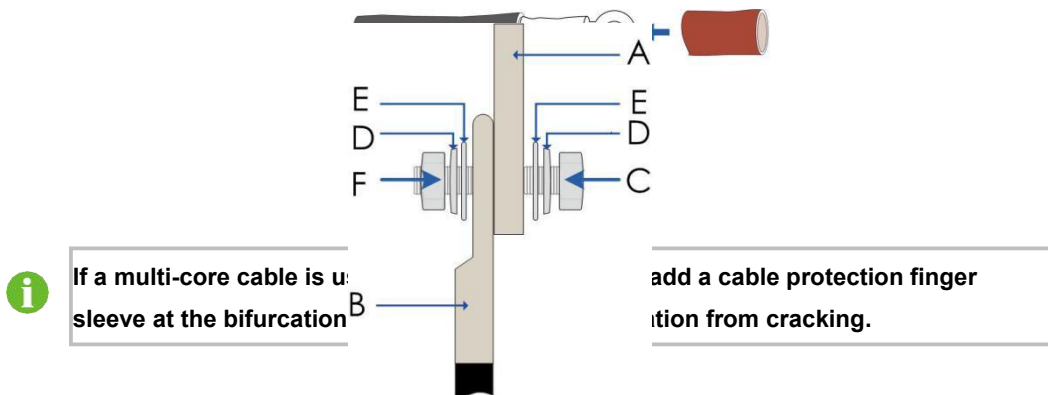

Step 7 Wiring.

- 1 Select the screws that match the wiring copper nose.
- 2 Crimp the wiring copper nose to the DC wiring copper bar.
- 3 When using copper wire to connect, the wiring sequence and components are as follows.

No.	Name	No.	Name
A	copper bar	D	spring pad
B	copper terminal	E	Flat pad
C	bolt	F	Nut

- When using aluminum wire for connection, the wiring sequence and components are as follows.

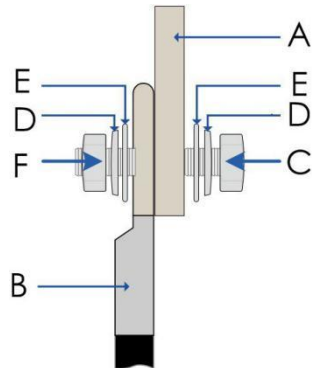

No.	Name	No.	Name
A	copper bar	D	spring pad
B	Copper aluminum transition terminal	E	Flat pad
C	bolt	F	Nut

4 Use a screwdriver or wrench to tighten. If M12x40 bolts are used, the tightening torque is 60~70N.m.



Warning

- **Incorrect wiring sequence may cause fire. Please pay attention to the connection sequence of the wiring parts.**
- **When connecting, make sure that the connector is tight. Inadequate connections or oxidation of the contact surfaces can also cause excessive heat, which may result in fire.**

Notice

- The length of the wiring screws should be appropriate, and it is enough to expose the mounting holes of the copper bars slightly. Too long may affect the insulation performance or even short-circuit.
- Check whether there is a part of the heat-shrinkable sleeve clamped at the connection between the terminal and the copper bar. If it is clamped, it should be removed immediately, otherwise it may cause poor contact or even heat damage.
- Make sure that the terminal and the copper bar are in good and tight connection and have good contact.

Step 8 Confirm whether the wiring terminal is fastened in place.

-- End the wiring and cover the low-voltage cabinet cover.

6. 3. 3 Medium voltage wiring

The connection terminals of the MVS and external medium voltage equipment are located inside the ring network cabinet.

On site, refer to the manual of the ring network cabinet for wiring.

Notice

During the wiring process, be sure to pay attention to the phase sequence of the wiring terminals.

6. 3. 4 Communication wiring

Before leaving the factory, the communication terminals of all equipment inside the MVS have been connected to the communication box. The operating data of these devices are uploaded to the background monitoring system through the communication box.

6. 3. 5 Auxiliary power supply wiring

There are spare sockets reserved inside the power distribution cabinet, as shown in the following figure. On site, perform wiring according to port identification and wiring drawings.

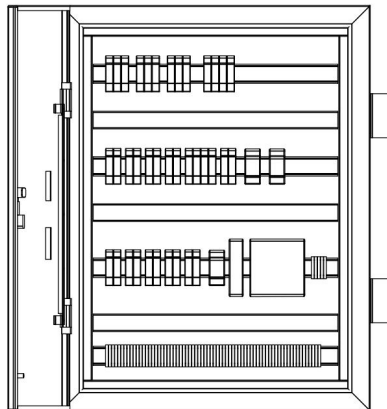

6. 4 Check after wiring is completed

Inspection items	Acceptance criteria
Equipment appearance	The appearance of the equipment is complete without damage, rust and paint peeling. If there is paint peeling, please carry out touch-up operation. Equipment labels are clearly visible. Damaged labels should be replaced promptly.

Cable appearance	<p>The protective cable wrapping is intact and there is no obvious damage.</p> <p>The threading cable and hose are in good condition.</p>
Cable connection	<p>The cable connection location is the same as the design.</p> <p>The terminals are made in accordance with the specifications, and the connection is firm and reliable.</p> <p>The labels at both ends of each cable are clear, and the labels are oriented in the same direction.</p> <p>The wiring meets the principle of strong and weak electricity separation.</p>
Cable arrangement	<p>The cables are neat and beautiful.</p> <p>The wire buckle joints are cut neatly, and no spikes are exposed.</p> <p>Allowance shall be reserved at the turning as required and shall not be tightened. The cables are straight and smooth, and the cables in the cabinet do not cross.</p>
Cabinet cleaning	<p>The inside of the box is clean and tidy, free of excess cables, wire ends, terminals and tools.</p> <p>There is no obvious sundries outside the equipment.</p>
Other	<p>Check the bottom of the MVS and seal the gaps between the cables with refractory mud.</p> <p>If using a cable gland, be sure to tighten it.</p> <p>Seal unused terminals.</p> <p>Reinstall the removed protective net cover. Waterproof treatment shall be carried out at the bottom of the MVS.</p>

7 Power transmission operation

Notice

The operations described in this subsection should only be performed by professionals and in accordance with local standards/regulations.

7. 1 Inspection before power transmission

7. 1. 1 Cabinet inspection

NO.	Inspection item
1	Installation meets design requirements.
2	The bottom of the cabinet is horizontal, and each cabinet door can be opened and closed flexibly
3	There are no cracks, dents or scratches on the surface of the cabinet. If necessary, repaint the paint falling area.
4	At least two grounding points of each cabinet should be grounded reliably, and the grounding resistance should be less than 4Ω .
5	The number and location of external accessories are consistent with the attached documents.
6	All markings are correct, clear and complete.

7. 1. 2 Medium voltage ring network cabinet

NO.	Inspection item
1	There are no cracks, dents or scratches on the surface of the cabinet.
2	The pointer of SF6 barometer is located in the green area.
3	Rotate the current terminal, disconnect the scriber for the current terminal, and measure the resistance at both ends. The value of the three-phase resistance should be small and close. After measurement, return the current terminal to the connected position and tighten. The backup current loop needs to be short-circuited and grounded.
4	Disconnect the yellow and green wires of the secondary circuit grounding wire, measure the resistance of the secondary circuit to ground. The resistance should be $1M\Omega$ or more, the ground wire is restored, and the resistance becomes 0.5Ω or less.

NO.	Inspection item
5	If conditions permit (with a relay protection tester or current source), check the setting of the protection device, including the setting, control word, and soft pressure plate. The setting must exactly match the setting sheet provided by the user.
6	Confirm that the trip pressure platen is put into use.
7	The cable compartment door is closed.
8	The auxiliary AC power supply air switch in the cabinet is closed.
9	The remote local switch is in the remote position.
10	The local switch operating hole is padlocked.
11	The load switch is opened and the grounding switch is closed.
12	Remove all foreign objects in the medium-voltage ring network cabinet, such as tools and remaining installation materials.

7. 1. 3 Medium voltage transformer

NO.	Inspection item
1	Confirm that there are no cracks, dents and scratches on the surface of the transformer.
2	Confirm that there is no oil leakage on the surface of the transformer.
3	The pointer of the transformer oil level gauge is at a low oil level in the normal working range.
4	The transformer oil temperature indication is close to the ambient temperature, the cover of the oil temperature gauge is installed tightly, the surface is clean, and the glass is not damaged. The cover of the oil thermometer shall be firmly installed and the surface shall be clean and intact. The temperature measurement loop is complete.
5	When the oil temperature is 20°C, the scale of the transformer oil thermometer will be displayed at "4".
6	The locking mechanism of the pressure relief valve has been removed and the pressure relief valve is not working. If not, follow the steps shown in Figure 7-1 Removing the Pressure Relief Valve Lockout to remove the lockout.
7	Install the respirator, disassemble the sealing plate on the respirator mounting plate and install the respirator.
8	The pressure gauge shows at 0.

NO.	Inspection item
9	<p>The no-load tap-changer gear is placed according to the user's set value requirements.</p> <p>If the customer does not have a fixed value, it is placed in the rated gear (five gears for conventional transformers, and the third gear is the rated gear), and the gear fixing bolts need to be fastened into the gear slot. After inspection, close the protective cover of the gear switch.</p>
10	<p>There is no packaging residue on the transformer surface and no debris in the transformer room.</p>
11	<p>Check the outside air insulation distance. Whether the air insulation distance between bushings of different voltage levels and grounding complies with relevant standards.</p>
12	<p>The oil leakage port of the transformer room is not blocked.</p>
13	<p>The transformer room mesh door is closed and locked.</p>

Remove locking device

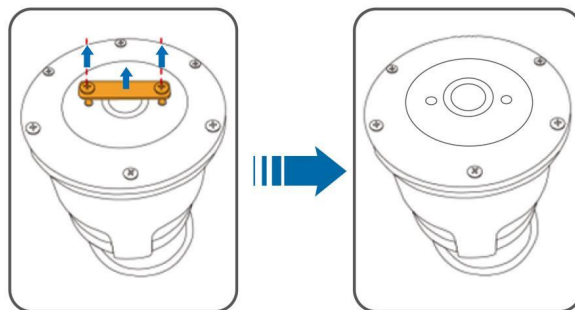

Figure 7-1 Removing the Pressure Relief Valve Locking Device

Adjust the no-load step switch

The transformer output voltage is adjusted by operating the step switch. When operating the step switch, please ensure that the transformer is in a non-excited state, that is, there is no electricity on the high and low voltage sides of the transformer. When the voltage on the low-voltage side remains unchanged, the output voltage on the high-voltage side in different gears is:

Gear	Output Voltage
1	Rated voltage x 1.05
2	Rated voltage x 1.025
3	Rated voltage x 1
4	Rated voltage x 0.975
5	Rated voltage x 0.95

Taking gear 1 as an example, the steps for adjusting the voltage ratio are shown in the figure below.

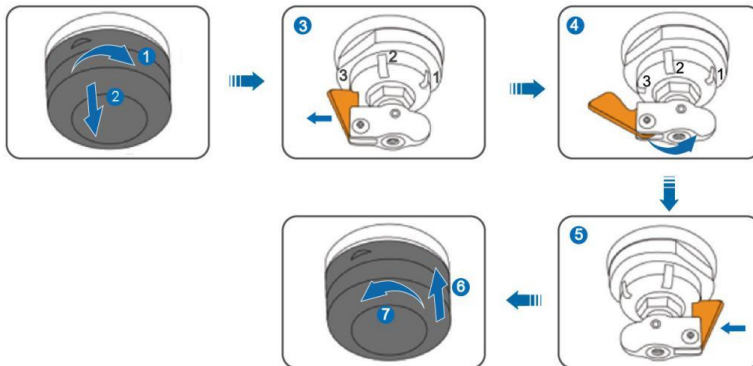

Figure 7-2 Adjusting the Voltage Ratio by Step Switching

7. 1. 4 Low voltage cabinet

NO.	Inspection item
1	Molded case circuit breakers are in the open position.
2	There is no obvious deformation of the copper bar, and no sundries are placed on the copper bar.
3	Measure the ground resistance of the incoming and outgoing copper bars of the circuit breaker. In the transformer neutral point ungrounded system, the incoming and outgoing line-to-ground resistance should be $M\Omega$; in the neutral grounding system, the outgoing copper bar resistance is $M\Omega$ and the phase-to-phase resistance is also $M\Omega$ class. (The auxiliary transformer circuit breaker needs to be disconnected, otherwise the phase-to-phase resistance is basically 0Ω .)
4	Measure the fuse resistance, the three-phase resistance should be small and the resistance value should be close.
5	The status indication of lightning arrester is green.
6	Move the scribe of the current terminal to the breaking position, and measure the resistance at both ends of the fracture. The value of three-phase resistances should be small and close. After the measurement is completed, restore the current terminal to the connected position and tighten it. The backup current loop needs to be short-circuited and grounded.
7	Disconnect the yellow-green wire of the secondary circuit grounding wire, measure the resistance of the secondary circuit to ground, the resistance should be $M\Omega$, the grounding wire is restored, and the resistance becomes less than 0.5Ω
8	The installation bolts of the incoming cables are fastened, and the cables are not loosened by pulling.
9	The plugging of incoming line hole has been completed.
10	There is no damage to the appearance of each component.
11	Remove all foreign objects in the switchgear, such as tools, remaining installation materials, etc.

7.2 Power transmission steps

Notice

After running for 24 hours under no-load state and ensuring that there is no abnormality, the MVS can be run with load.

Handover test, system power on and other operations must be carried out by local qualified electricians according to national / local standards.

8 Troubleshooting

This chapter only lists common troubleshooting methods on the transformer side. For more details, please refer to the relevant transformer and ring network cabinet user manuals.

Fault phenomenon	Possible reason	Troubleshooting method
Pressure relief valve tripped	1. Internal short-circuit fault of the transformer.	If it is a short circuit fault, perform oil chromatographic analysis to further determine the cause of the fault. It is strictly forbidden to put the transformer into operation before the cause of the fault has been determined and the fault has not been solved. (Note: If it is determined that the internal fault is serious, it means that the inside of the transformer is damaged, please contact our company for replacement.)
	2.The pressure relief valve is faulty.	The elastic expander on the pressure release valve is stuck inside, or the torque of the bolts that fasten the membrane is too large, causing the membrane to be damaged. Please contact our company for replacement.
	3.Improper oil filling before maintenance or installation of transformer. The pressure relief valve locking device on the oil tank is not opened as required	After turning off the power, open the oil hole to release the pressure in the oil tank.

Low oil level trip	1.Secondary circuit causes false alarm of low oil level.	Check the secondary circuit and check whether there is fault.
	2.The transformer leaks oil or leaks for a long time. After draining the oil for maintenance or testing reasons, the oil was not replenished to the normal oil level in time.	Fill the transformer with oil.
Oil temperature alarm	1.Transformer overload operation. Overload operation may cause a high oil temperature alarm.	Check whether the transformer is overloaded.
	2.The cooling channel is blocked.	Check whether the cooling channel of the transformer is blocked by foreign matters.
	3.The secondary circuit causes the oil temperature alarm.	Check the actual oil temperature of the transformer to see if it is a false alarm.
Oil temperature jump	1.The transformer is overloaded.	Check whether the oil level of the transformer is too low.
	2.Internal fault of the transformer.	Check whether the temperature sensor is abnormal.
	3.Transformer secondary circuit fault. Long term overload operation will cause the temperature of the transformer to continue to rise, resulting in overcurrent and high-voltage tripping.	Check the load on the transformer. Check the load with the internal ammeter of the low voltage cabinet. In case of tripping due to overload, it is recommended to reduce the operating load.

9 Routine maintenance

Due to the influence of ambient temperature, humidity, dust and vibration, the components inside the MVS will age and wear out, which will lead to potential failures inside the MVS. Therefore, it is necessary to carry out routine and regular maintenance on the MVS to ensure its normal operation and service life.

All measures and methods that help the MVS to be in good working condition belong to the scope of maintenance work.

9.1 Safety Precautions

Warning

There is a fatal high voltage in the equipment inside the MVS. If accidentally touched, there is a danger of fatal electric shock. After shutdown, please wait at least 10 minutes before opening the door. Before performing maintenance work, make sure that the inside of the device is completely de-energized.

Warning

Only qualified and authorized personnel may perform operations such as maintenance on the MVS.

During maintenance, do not leave metal parts such as screws and washers in the MVS, otherwise the equipment may be damaged!

Warning

The entry of wind, sand and moisture may damage the electrical equipment in the MVS or affect the operation performance of the equipment!

- Do not open the equipment cabinet door in the MVS in the wind and sand season or when the relative humidity in the surrounding environment is greater than 95%.
- Maintenance work can only be started when there is no wind and sand and the weather is clear and dry.

Warning

If only the switches on the low-voltage side and high-voltage side of the AC side are disconnected, the cable connection terminals inside the MVS are still live! To avoid the danger of electric shock, before maintenance, inspection, etc.:

- Disconnect all internal switches.
- Disconnect the switches of all equipment at the front and rear stages of the MVS.

In order to ensure the safety of operators when maintaining or overhauling the MVS, be sure to abide by the following **five safety rules** :

- Professionals ensure that MVSs cannot be re-energized accidentally .
- Use electrical inspection equipment to ensure that the inside of the MVS is completely de-energized.
- Have the necessary ground and short-circuit connections made by professionals.
- For possible live parts near the operating part, use insulating cloth to cover them. Check whether the escape route is blocked.

9.2 Maintenance

9.2.1 Overview

The MVS has IP54 protection grade and is suitable for outdoor use. However, harsh environment or long-term operation will cause the aging of the MVS or damage to the internal equipment. Regular maintenance and inspection of the MVS, and replacement of aging and damaged components will effectively prolong its service life and improve the performance of internal equipment.



Irregular inspection is necessary, especially when the overall performance of the system is poor.

9.2.2 Maintenance period

In order to ensure the good operation of the equipment in the MVS, the MVS should be maintained regularly.

The maintenance intervals given in this section are reference values. The actual maintenance period should be reasonably determined based on the actual environmental conditions of the project site. If the operating environment of the MVS is relatively harsh, such as in a desert area, the corresponding maintenance period should be shortened. In particular, internal and external cleaning, anti-corrosion and anti-rust work, etc., should be more frequent.

If the MVS is installed in a desert area, it is recommended that the inside and outside of the MVS should be carefully inspected and thoroughly cleaned after each sandstorm.



Warning

Failure to comply with the torque requirements may cause fire at the connection! During the electrical connection process, the bolts must be tightened strictly to the torques described in this manual.



Warning

- **Incorrect wiring sequence may cause fire. Please pay attention to the connection sequence of the wiring parts.**
- **When connecting, make sure that the connector is tight. Inadequate connections or oxidation of the contact surfaces can also cause excessive heat, which may result in fire.**

9.3 Maintenance items

Routine inspection and maintenance must comply with the relevant regulations of the power company. Inspection, maintenance and repair can only be performed by trained personnel who are familiar with the equipment. Personnel must be certified and comply with safety regulations issued by the power company.

Inspection item	Inspection method	Period
System Status and Cleaning	Check whether the MVS and internal equipment are damaged or deformed.	Once a month
	Check whether there is abnormal noise during the operation of the internal equipment.	
	Check whether the temperature inside the MVS is too high.	
	Check whether the temperature inside the MVS is too high.	
	Check that warning signs, labels, etc. are clearly visible and not defaced. Replace if necessary.	
	Check whether the humidity and gray scale are too heavy, and clean the equipment if necessary.	
	check whether there is oxidation or corrosion inside the MVS. If present, refer to rust removal.	

Inspection item	Inspection method	Period
Cable connection	Check whether the power cable is loose. If it is loose, tighten it according to the torque specified in the manual.	Once every half a year after the first commissioning and once every two years thereafter.
	Check whether the power cables and control cables are damaged, especially whether the skin in contact with the metal surface has any signs of cuts.	
	Check whether the insulating wrapping tape of the power cable terminal is peeled off.	
Fan / heat exchange	Clean or replace the dust filter.	Once every half a year after the first commissioning, and once every half a year to once a year thereafter.
	Check the operating status of the fan/heat exchanger.	
	Check whether the fan / heat exchanger makes abnormal sound during operation.	
Equipment maintenance	For maintenance of various internal equipment, please refer to relevant manuals.	—
Medium voltage ring network cabinet	Check the SF6 barometer to see if the pointer is within the green range. If the pointer approaches red, please stop the operation and replenish gas to it.	Once a month
	Check the live indicator and check whether the L1 / L2 / L3 indicator is normal. If it is abnormal, please replace the L1/L2/L3 indicator lights when the power is off.	

Inspection item	Inspection method	Period
Transformer	Check the transformer oil level indicator. If the oil level is low, please power off the MVS and fill in oil in time.	Once a month
	Check whether there is oil leakage around the pressure relief valve. If yes, tighten the valve.	
	Check the sheath of low-voltage cabinet and high-voltage cabinet to see if there is oil leakage. If yes, tighten the valve. Check whether there is oil leakage at the joint between the transformer radiator and the oil tank flange. If yes, please tighten the valve in time.	
	Check whether the real-time temperature of the oil thermometer is normal. If abnormal, measure the resistance of PT1/PT2 and PT3 with a multimeter. If the result is unqualified, it means that the temperature controller is faulty and needs to be repaired in time.	
	During operation, check whether the sound of the transformer is normal.	
Low voltage cabinet	Check whether the lightning arrester indicator is normal (green) or faulty (red).	Once a month
	Check for condensation on interior side panels and top cover.	
Other equipments	Replace damaged lamps promptly.	when necessary
	Replace damaged smoke sensors and fire extinguishers promptly.	
	Replace the temperature and humidity controller in time.	

9.4 Transformer oil drain operation

Oil drain valve

The oil drain valve is located at the bottom of the transformer.

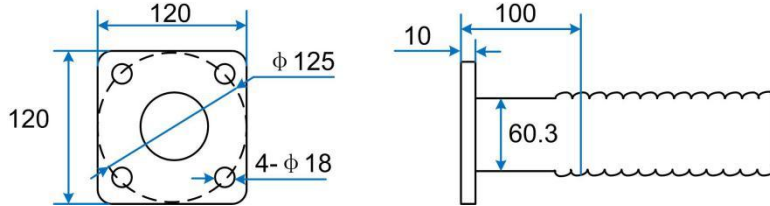

Preparation of installation tools

Tools that may be used:

Gear	Name	Component source
1	Cleaned steel hoses and oil tanks	
2	Rag	
3	Wrench	Not included in the scope of supply
4	300mmx38mm adjustable wrench	
5	Oil drain hose connector	
6	Pipe clamp	



*The capacity of the oil tank must be greater than $N \times 200L$, and N represents the amount of oil to be released.

Operation

Step 1 Remove the oil drain valve cover.

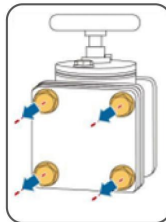

Step 2 Fix the oil drain hose connector. One end of the steel hose is connected to the oil drain hose connector, and the other end is connected to the oil tank.

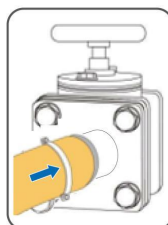

Step 3 Open the oil drain valve, and the transformer oil slowly flows from the transformer into the oil tank.

Step 4 When no oil flows out of the transformer, stop draining the oil.

Step 5 Close the oil drain valve and remove the oil drain hose connector and hose.

Step 6 Reinstall the cover of the oil drain valve.

- - Finish

9.5 Paint repair measures

Check the appearance of the cabinet for damage:

Case 1: Surface dirt caused by water stains and dust can be cleaned

Case 2: The surface is dirty & the topcoat is damaged, and the surface traces cannot be cleaned.

Case 3: The primer is damaged and the substrate is exposed.

Operation steps for maintenance in case 1:

Material:

- rag
- water
- Alcohol or other non-corrosive cleaner

Illustration



Step

1. Use a rag (or other scrubbing tool) dampened with water to scrub the dirty parts of the surface.

2. If it cannot be cleaned with water, scrub with 97% alcohol until the surface cleanliness reaches an acceptable range. (You can also try to use a non-corrosive cleaner commonly used in your area).

Operation steps for maintenance in case 2:

Material:

- Sandpaper
- Rag
- Water
- Alcohol
- Brush
- The color number is RAL7035 paint

Illustration**Step**

Use sandpaper to polish the rough or scratched parts of the surface paint to make the surface smooth.



Using a cloth dampened with water or 97% alcohol, scrub the damaged area to remove surface stains.







After the surface is dry, use a soft brush to touch up the scratched parts of the paint, and try to keep the paint brushing as uniform as possible.

Operation steps for maintenance in case 3:

Material:

- Sandpaper
- Rag
- Water
- Alcohol
- Zinc rich primer
- Brush
- The color number is RAL7035 paint

Illustration	Step
	<p>1. Use sandpaper to polish the rough or scratched parts of the surface paint to make the surface smooth.</p>
	<p>2. Using a cloth dampened with water or 97% alcohol, scrub the damaged area to remove surface stains and dust.</p>
	<p>3. After the surface is dry, spray zinc-rich primer to protect the exposed parts of the substrate. The coating shall completely cover the exposed substrate.</p>
	<p>4. After the primer is dry, use a soft brush to touch up the damaged parts, and try to keep the paint brushing as uniform as possible.</p>



It is necessary to check whether the protective paint sprayed on the shell of the MVS has peeled off, peeled paint, etc. If found, please repair it in time. The entire exterior of the MVS should be repainted with special protective paint every 5 years.

10 Appendix

10.1 **Technical data** (reference data of the manual prototype, the specific parameters are subject to the agreement)

7MW 33kV:

NO.	Name	
I	Step-up MVS	Winding material Al.
1	Type	Containerized
2	Rated Voltage (KV)	33
3	Maximum Voltage (KV)	36
4	Rated Frequency (Hz)	50
5	Rated Current (A) MV/LV-LV	135/2526-2526
6	Insulation Class(KV)	LI 170 AC70 /LI AC2.2
7	Insulation Thermal Class	Class A
8	Lightning Impulse Withstand Voltage	170kV
9	Power Frequency Withstand Voltage	70kV/80kV
10	Thermal Current (R.M.S. KA/2s)	20
11	Dynamic Current (Peak KA)	50
12	Weight(t)	About 25
13	Size	20' HC
	Height(mm)	2896
	Length(mm)	6058
	Width(mm)	2438
14	Protection Class	IP54

NO.	Name	
II	Step-up Transformer	
1	Type:	Oil-immersed
2	Rated Capacity (KVA)	7000
3	Phases:	3
4	Winding material	AL
5	MV Winding Rated Voltage (KV) :	33
6	MV Maximum Voltage (KV)	36
7	LV Rated Voltage (KV)	0.8-0.8 (Matched with inverters output)
8	Rated Frequency (Hz)	50
9	Tap Changer:	$\pm 2 \times 2.5\%$
10	Connection of Winding:	D,y11-y11
11	Impedance Voltage (%)	8%
	L1L2-M	8(meet IEC60076.5)
	L1-M/L2-M(100% power)	15
	L1-L2	26
12	Power Frequency Withstand Voltage (KV)	
	1) MV:	70
	2) LV:	3
13	Lightning Impulse Withstand Voltage (KV) (Peak)	LI 170
14	Noise (dB)	≤ 55 dB
15	Insulation Thermal Class	A

NO.	Name	
16	Shell Protection Class	IP68
17	Partial Discharge	Meet IEC Standard
18	Temperature Rise Limitation (K)	Top Oil: 60K Winding: 65K
19	Rated Ratio, Losses at 75°C ,(Power Factor of 1)	
	– Full Load	(meet PEI 99.178%)
	– 3/4 Load	(meet PEI 99.347%)
	– Half Load	(meet PEI 99.502%)
	– 1/4 Load	(meet PEI 99.58%)
	No Load Losses(W)	4000W
	Load Losses(W)	54000W
20	Minimum Peak Efficiency Index	99.58%(EU No 548 T2)
21	Protection	Oil temperature, oil level, pressure, Buchholzrelay, winding temperature
III	RMU (MV Circuit Breaker)	RMU
1	Type	SF6
2	Rated Voltage (KV)	35
3	Rated Current (A)	630
4	1min power frequency withstand voltage (KV) phase to phase, to earth/fracture 1min	95/118
5	Lightning impulse withstand voltage (KV) phase to phase, to earth/fracture	185/215

NO.	Name	
6	Rated break current (KA) Rated break current (KA)	20/1S
7	Dynamic Current (KA)	50
8	Thermal Current (KA/s)	20/1
9	Protection	50/51, 50/51N
IV	RMU (MV Load Switch)	RMU
1	Type	SF6
2	Rated Voltage (KV)	35
3	Rated Current (A)	630
4	Maximum Voltage (KV)	40.5
5	1min power frequency withstand voltage (KV) phase to phase, to earth/fracture 1min	95/118
6	Lightning impulse withstand voltage (KV) phase to phase, to earth/fracture	185/215
7	Thermal Current (KA/s) 热电流 (KA/s)	20/1
V	MV Surge Arrester	
1	Type	Metal-oxide surge arresters without gaps
2	Rated Voltage (KV)	51
3	Operating Voltage (KV)	134

NO.	Name	
4	Nominal discharge current (KA)	5
5	Lightning Impulse Residual Voltage (8/20 μ S, 5kA)(KV)	134
6	1mA DC Reference Voltage (KV)	73
7	Current Flow Capacity (2ms) (A)	>150
8	Large Current Impulse Withstand	Meet IEC 60099-4
9	Large Current Discharge Current Class	Meet IEC 60099-4
VI	LV ACB	
1	Installation type	Fixed
3	Phases	3
4	Rated Voltage (V)	800
5	Frame Rate Current	4000
6	Trip Rated Current (A)	3200
7	Rated limit short-circuit breaking capacity Icu (KA)	50
8	Rated operating short-circuit breaking capacity Ics (KA)	50
9	Rated short-circuit making capacity Icm (peak value) (KA)	110
10	Rated short-time withstand current Icw (effective value)1s (KA)	50
11	control Type	Magnetic (the overload, short circuit, grounding etc.)

NO.	Name	
VII	LV MCCB	
1	Type	MCCB
3	Phases	3
4	Rated Voltage (V)	800
5	Frame Rated Current (A)	250
6	Trip Rated Current (A)	250
7	Rated limit short-circuit breaking capacity Icu: (KA)	50
8	Rated operating short-circuit breaking capacity Ics: (KA)	35
9	control Type	Thermal
VIII	LV CT	
1	Type	dry
2	Rated current Ratio	3000/1A
3	Secondary Rated Capacity (VA)	15
4	Accuracy Class	0.5
IX	Auxiliary Transformer	
1	Type:	Copper winding Dry type
2	Rated Capacity (KVA)	10
3	Phases:	3
4	primary rated voltage: (KV) :	0.8
5	Primary maximum voltage: (KV)	1
6	Second rated voltage: (KV) Second rated voltage: (KV)	0.4/0.23

NO.	Name	
7	Frequency (Hz)	50
XI	Intelligent Integrated Measurement and Protection Device	Y,Outlet:RS485

*Parameters are subject to specific projects.

Table 10-1 Comparison table of rated current and short-circuit breaking current

10.2 Tightening torques

In order to prevent the connection copper nose from being loosened by force, causing poor contact, or increasing the contact resistance and causing heat or even fire, it should be ensured that the following torque requirements should be met when tightening the screws of the connection copper nose:

Brand	Rated voltage	Frequency	Rated current	Short circuit breaking current
ABB	24kV	50Hz	630A	20kA
		60Hz	600A	
	36kV	50Hz	630A	20kA
		60Hz	600A	
Siemens	24kV	50Hz	630A	20kA
		60Hz		
Ormazabal	36kV	50Hz	630A	20kA
		60Hz		

In order to reduce the stress on the wiring copper nose, the cable shall be fixed at an appropriate position.

Screw	Torque (N m)	Screw	Torque (N m)
M3	0.7~1	M8	18~23
M4	1.8~2.4	M10	34~40
M5	4~4.8	M12	60~70
M6	7~8	M16	119~140

10.3 **Contact information**

If you have any questions about this product, please contact us. In order to provide you with faster and better after-sales service, we need your assistance to provide the following information:

- Equipment model
- Equipment serial number
- Fault code / name
- Simple description of fault phenomenon